

ZERO-MAX

CD[®] Couplings



CD[®] Couplings for the Most Challenging Motion Applications

- For today's most demanding servo motor and motion control applications. CD Couplings are **precise, robust,** and **available** in sizes and models for every application
- **Zero Backlash** for use in precision applications
- High **torsional stiffness** and high **dynamic load capacity** ensure reliable machine operation
- **Precise** positioning under **high speed** reversing loads without fatigue for reliable 24/7 operation
- Unique patented Composite Disc design provides **high misalignment capacity** and **long operational life**
- **Clamp style hub** designs provide a **superior** method of shaft attachment
- Eco-Friendly, adapted to **RoHS** Directive with no banned substances

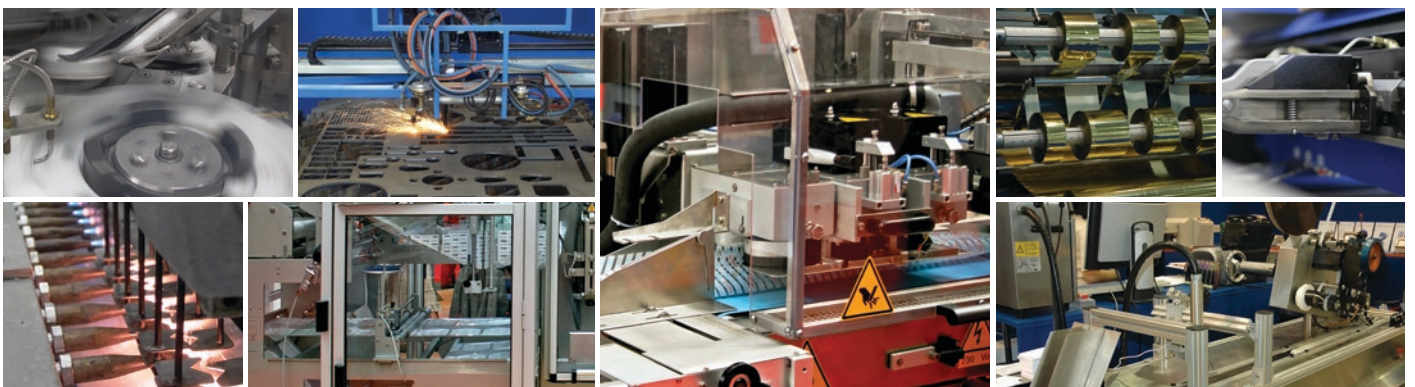
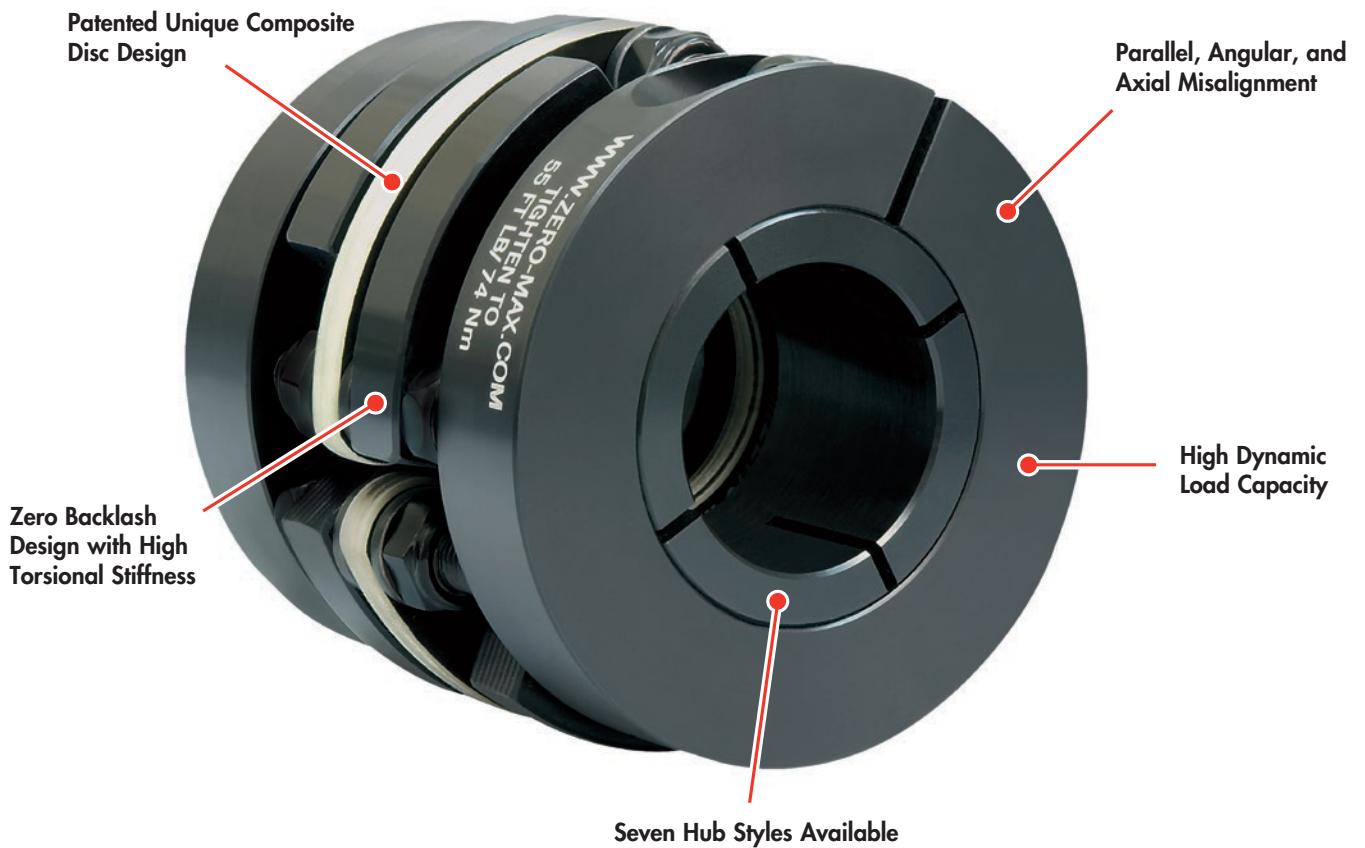

CD Couplings allow you to transmit high torque in a small envelope. They are ideal for cyclic applications where speed and repeatable accuracy are critical to keep 24/7 systems going.

CD Couplings withstand the punishment and stress of a servo motor. In comparison, other couplings may have high torsional stiffness specifications; however, they can be too brittle to withstand the punishment of high speed reversing applications and shaft misalignments.

Standard and Custom CD Couplings are available for every application. Do you need higher misalignment and greater torque capacity in your coupling? Need more flexibility and torsional stiffness? Need a very large bore diameter coupling? Or a long floating shaft coupling? Zero-Max CD Couplings are available in a full range of styles, models and sizes to meet those needs. Zero-Max will design and build a custom CD Coupling to handle your unique application. **See Page 19.**

Composite Disc (CD) Advantages:

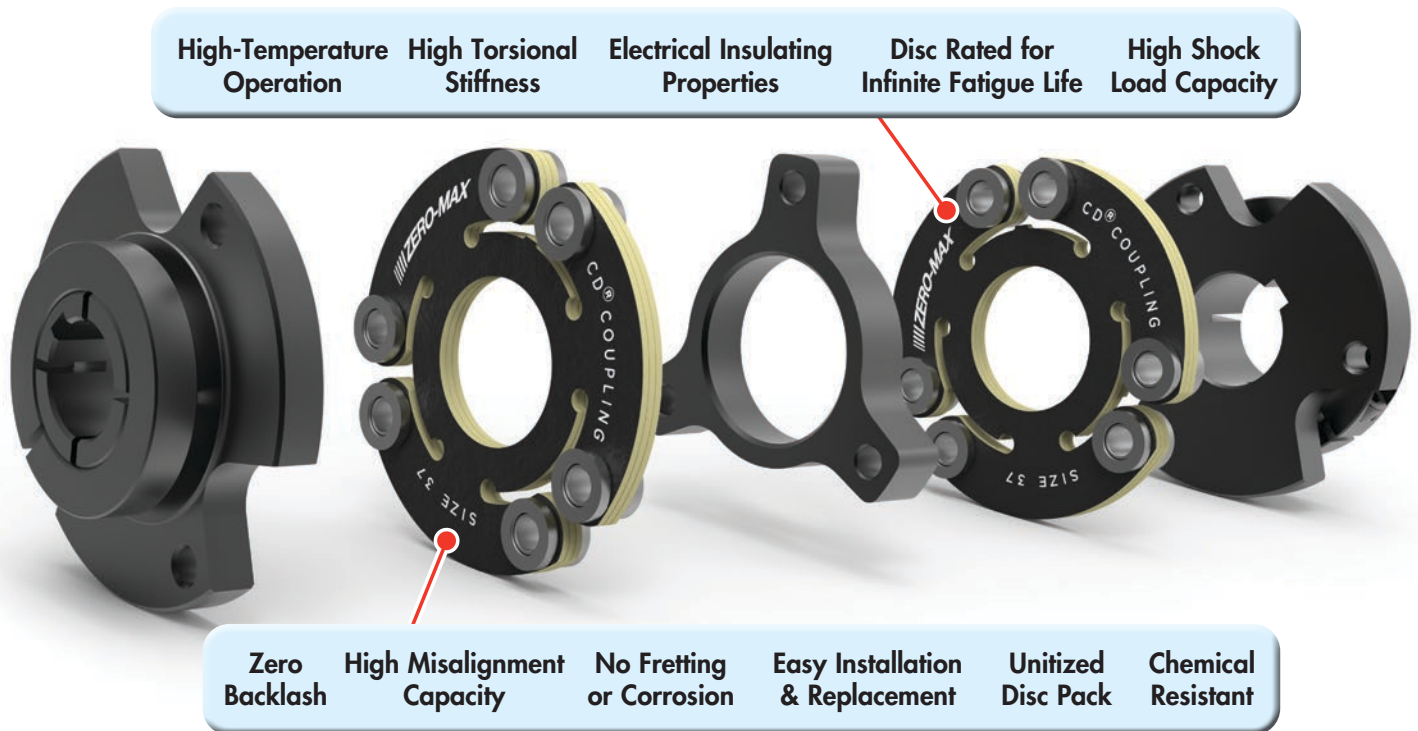

- Available in single disc, double disc, floating shaft, and custom models
- Single and double disc models available in steel or aluminum clamp style hubs
- Operating temperature range is -70° to +250°F (-57° to + 121°C)
- Composite Discs are resistant to many chemicals
- Hubs are machined to a high level of concentricity for smooth and quiet operation

- Steel, Aluminum, Stainless Steel, and Plated construction options
- Maintenance free
- Ideal for high precision applications including packaging machines, pick and place systems, printing machinery, machine tools, and most systems using servo motors
- RoHS compliant – manufactured of RoHS compliant materials and contains no banned substances

The Single Flex Composite Disc Coupling is an excellent choice for zero backlash applications. The unique design delivers two features that are not often found in a precision coupling. High torsional stiffness and high durability!

The compact size and clamping system allow this coupling to fit into many applications. This design is also capable of being used in very high speed applications with slight modifications.

- Zero Backlash
- Torsionally Stiff
- Excellent for Reversing Loads
- Smooth Operation at High Speeds
- Misalignment Capacity
- Compact



Available with or without keyway on clamp style hubs

Performance Information

	Continuous Rated Torque	Peak Rated Torque	Torsional Stiffness	Maximum Speed		Misalignments			A Hub		B Hub		Clamp Hub		QD Hubs Unit Weight w/ Bushing
	in-lbs (Nm)	in-lbs (Nm)	in-lbs/deg. (Nm/Rad)	A & B Hub (RPM)	Clamp Style Hub (RPM)	Angular Degrees	Parallel Inch (mm)	Axial Inch (mm)	Unit Weight at Max Bore Lb (kg)	Unit Inertia at Max Bore lb-in ² (kg-cm ²)	Unit Weight at Max Bore Lb (kg)	Unit Inertia at Max Bore lb-in ² (kg-cm ²)	Unit Weight at Max Bore Lb (kg)	Unit Inertia at Max Bore lb-in ² (kg-cm ²)	Lb (kg)
6A18 6A18C	180 (20)	360 (40)	1,800 (11,650)	14,000	12,000	3	0.004 (0.10)	0.030 (0.8)	0.43 (0.2)	0.16 (0.47)	-	-	0.82 (0.37)	0.35 (1.02)	-
6A22 6A22C	270 (30)	540 (60)	2,680 (17,352)	12,000	11,000	3	0.006 (0.15)	0.036 (0.9)	0.88 (0.4)	0.49 (1.45)	0.96 (0.44)	0.66 (1.92)	1.57 (0.71)	1.08 (3.16)	-
6A26 6A26C	475 (53)	950 (106)	3,100 (20,100)	10,500	9,500	3	0.008 (0.20)	0.043 (1.1)	1.37 (0.62)	0.93 (2.72)	1.37 (0.62)	1.21 (3.54)	1.83 (0.83)	1.57 (4.58)	-
6A30 6A30C	800 (90)	1,600 (180)	6,638 (42,976)	9,000	8,000	3	0.010 (0.3)	0.050 (1.3)	2.0 (0.9)	1.88 (5.50)	2.5 (1.1)	2.84 (8.30)	3.51 (1.59)	4.07 (11.9)	-
6A37 6A37C 6A37QD	1,600 (181)	3,200 (362)	10,374 (67,167)	7,400	6,700	3	0.013 (0.3)	0.070 (1.8)	3.6 (1.6)	5.57 (16.3)	4.2 (1.9)	7.86 (23.0)	6.00 (2.72)	11.7 (34.2)	3.7 (1.7)
6A45 6A45C 6A45QD	2,500 (282)	5,000 (564)	19,138 (123,909)	6,100	5,600	3	0.015 (0.4)	0.090 (2.3)	6.4 (2.9)	14.6 (42.7)	7.2 (3.3)	20.0 (58.5)	10.58 (4.80)	21.2 (62.0)	6.8 (3.1)
6A52 6A52C 6A52QD	3,560 (402)	7,120 (804)	26,049 (168,656)	5,200	4,800	3	0.018 (0.5)	0.110 (2.8)	10.5 (4.8)	32.4 (94.8)	11.4 (5.2)	43.2 (126)	14.65 (6.64)	53.0 (155)	11.7 (5.3)
6A60 6A60C 6A60QD	6,350 (718)	12,700 (1,436)	41,485 (268,595)	4,600	4,400	3	0.020 (0.5)	0.130 (3.3)	15.3 (7.0)	61.3 (179)	18.4 (8.4)	90.6 (265)	23.2 (10.5)	116 (340)	15.8 (7.2)
6A67 6A67C 6A67QD	10,300 (1,164)	20,600 (2,328)	61,948 (401,084)	4,300	4,100	3	0.022 (0.6)	0.150 (3.8)	22.0 (10.0)	111 (325)	26.5 (12.0)	163 (477)	35.0 (15.9)	205 (600)	20.5 (9.3)
6A77 6A77QD	15,600 (1,763)	31,200 (3,526)	94,107 (609,303)	3,900	-	3	0.025 (0.6)	0.160 (4.6)	31.3 (14.2)	209 (612)	38.5 (17.5)	318 (931)	-	-	29.5 (13.4)
6A90	25,000 (2,825)	50,000 (5,650)	160,653 (1,040,162)	3,600	-	3	0.030 (0.8)	0.180 (4.6)	49.9 (22.7)	461 (1,349)	62.6 (28.5)	722 (2,113)	-	-	-
6A105	34,900 (3,944)	69,800 (7,888)	244,204 (1,581,120)	3,300	-	3	0.035 (0.9)	0.210 (5.3)	81.5 (37.0)	1,046 (3,061)	98.3 (44.7)	1,572 (4,600)	-	-	-
6A120	47,200 (5,333)	94,400 (10,666)	328,095 (2,124,275)	3,000	-	3	0.040 (1.0)	0.250 (6.4)	124.0 (56.4)	2,054 (6,011)	141.0 (64.1)	3,100 (9,070)	-	-	-

- Consult factory for speeds higher than those listed and balancing requirements, if necessary.
- Consult factory for higher torque and higher torsional stiffness couplings.

Clamp Style Hub

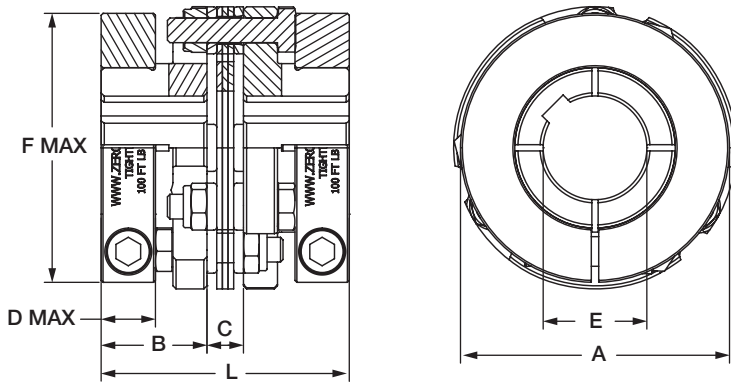

Dimensional Information

	A	B	C	D	Max Bore		F	H	L
					w/kwy	w/o kwy			
	Inch (mm)	Inch (mm)	Inch (mm)	Inch (mm)	Inch (mm)	Inch (mm)	Inch (mm)	Inch (mm)	Inch (mm)
6A18C	1.85 (47.0)	0.81 (20.6)	0.28 (7.1)	0.472 (12)	0.625 (16)	0.813 (21)	1.77 (45)	0.79 (20.1)	1.88 (47.8)
6A22C	2.25 (57.2)	1.00 (25.4)	0.31 (7.9)	0.551 (14)	0.750 (20)	0.938 (25)	2.21 (56)	0.98 (24.9)	2.31 (58.7)
6A26C	2.60 (66.0)	1.06 (26.9)	0.31 (7.9)	0.551 (14)	1.000 (24)	1.188 (30)	2.36 (60)	1.00 (25.4)	2.43 (61.7)
6A30C	3.00 (76.2)	1.25 (31.8)	0.46 (11.7)	0.709 (18)	1.125 (30)	1.375 (35)	2.92 (74)	1.21 (31)	2.96 (75.2)
6A37C	3.75 (95.3)	1.44 (36.6)	0.52 (13.2)	0.748 (19)	1.500 (40)	1.875 (48)	3.71 (94)	1.51 (38)	3.40 (86.4)
6A45C	4.50 (114.3)	1.69 (42.9)	0.58 (14.7)	0.866 (22)	1.750 (45)	2.250 (55)	4.29 (109)	1.81 (46)	3.96 (100.6)
6A52C	5.25 (133.4)	1.94 (49.3)	0.65 (16.5)	0.984 (25)	2.250 (60)	2.625 (65)	4.92 (125)	2.11 (54)	4.52 (114.8)
6A60C	6.00 (152.4)	2.44 (62.0)	0.77 (19.6)	1.339 (34)	2.625 (70)	3.000 (75)	5.71 (145)	2.42 (61)	5.64 (143.3)
6A67C	6.75 (171.5)	2.75 (69.9)	0.86 (21.8)	1.339 (34)	2.875 (80)	3.500 (90)	6.50 (165)	2.72 (69)	6.36 (161.5)

Performance Note: The torque capacity of keyless clamped hubs is governed by many factors, including shaft/hub bore diameter, clamp size, and other installation variables. Keyless coupling hubs with smaller bore sizes (approximately less than one-half the maximum bore listed) may not transmit the full torque rating of the coupling. Consult factory for further detail if your application is of high torque/small keyless shaft variety.

Dimensional Information

Set Screw Hub

QD Style Hub

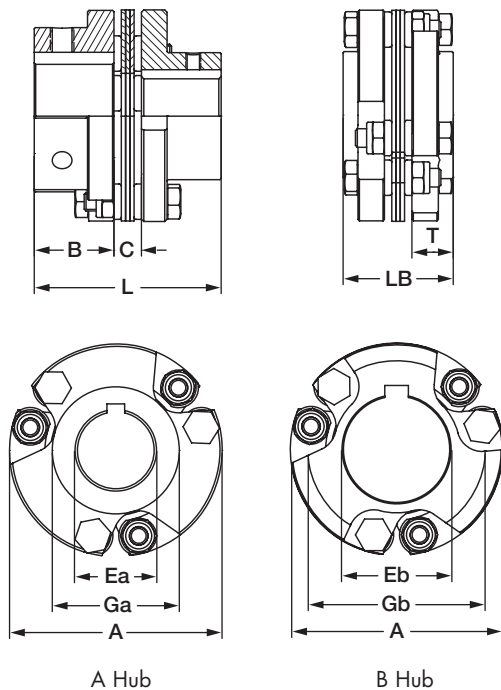

	A	B	C	Max Bore	Max Bore	Ga	Gb	H	L	X*	QD Only		
				Ea	Eb						LB	T	QD**
	Inch (mm)	Inch (mm)	Inch (mm)	Inch (mm)	Inch (mm)	Inch (mm)	Inch (mm)	Inch (mm)	Inch (mm)	Inch (mm)	Inch (mm)	Inch (mm)	Bushing Type
6A18	1.85 (47.0)	0.625 (15.9)	0.276 (7.0)	0.625 (16)	-	1.13 (28.6)	-	0.79 (20.1)	1.53 (38.8)	0.0 (0)	-	-	-
6A22	2.25 (57.2)	0.94 (23.8)	0.31 (7.8)	0.625 (16)	1.000 (26)	1.22 (31)	1.88 (47.6)	0.98 (24.9)	2.18 (55.4)	0.51 (13)	-	-	-
6A26	2.59 (66)	1.06 (27.0)	0.31 (7.8)	0.750 (19)	1.250 (32)	1.50 (38.2)	2.16 (54.8)	1.00 (25.4)	2.43 (61.7)	0.39 (9.9)	-	-	-
6A30	3.00 (76.2)	1.25 (31.8)	0.46 (11.7)	1.000 (25)	1.375 (35)	1.71 (43)	2.50 (64)	1.21 (31)	2.96 (75)	0.39 (9.9)	-	-	-
6A37 6A37QD	3.75 (95.3)	1.44 (36.5)	0.52 (13.3)	1.250 (32)	1.813 (46)	2.19 (56)	3.13 (79)	1.51 (38)	3.40 (86)	0.68 (17.3)	1.78 (45.2)	0.63 (16)	JA**
6A45 6A45QD	4.50 (114)	1.69 (42.9)	0.58 (14.8)	1.625 (42)	2.250 (60)	2.69 (68)	3.75 (95)	1.81 (46)	3.96 (101)	0.91 (23.1)	2.34 (59.5)	0.88 (22.4)	SH**
6A52 6A52QD	5.25 (133)	1.94 (49.2)	0.65 (16.4)	1.875 (45)	2.625 (66)	3.31 (84)	4.38 (111)	2.11 (54)	4.52 (115)	0.73 (18.5)	3.41 (87)	1.38 (35.1)	SD**
6A60 6A60QD	6.00 (152)	2.44 (61.9)	0.77 (19.5)	2.250 (60)	3.000 (76)	3.67 (93)	5.00 (127)	2.42 (61)	5.64 (143)	0.69 (17.5)	3.53 (90)	1.38 (35.1)	SD**
6A67 6A67QD	6.75 (172)	2.75 (69.9)	0.86 (21.8)	2.625 (65)	3.375 (85)	4.29 (109)	5.63 (143)	2.72 (69)	6.36 (162)	0.41 (10.4)	3.62 (92)	1.38 (35.1)	SK**
6A77 6A77QD	7.75 (197)	3.13 (79.4)	1.01 (25.7)	2.875 (75)	3.875 (100)	4.61 (117)	6.46 (164)	3.13 (79)	7.26 (185)	0.89 (22.6)	4.01 (102)	1.50 (38.1)	SF**
6A90	9.00 (229)	3.75 (95.3)	1.13 (28.8)	3.000 (75)	4.500 (120)	5.38 (137)	7.50 (191)	3.62 (92)	8.63 (219)	1.39 (35.3)	-	-	-
6A105	10.50 (267)	4.25 (108)	1.45 (36.8)	3.750 (95)	5.125 (130)	6.11 (155)	8.75 (222)	4.23 (107)	9.95 (253)	1.92 (48.8)	-	-	-
6A120	12.00 (305)	4.75 (121)	1.54 (39.0)	4.250 (110)	6.000 (152)	7.34 (186)	10.00 (254)	4.83 (123)	11.04 (280)	1.48 (37.6)	-	-	-

*"X" dimension is the minimum bolt travel required beyond the hub to disassemble the disc pack from the hubs.

**QD Bushings not included with coupling. Customer supplied. Customer must verify bushing torque value.

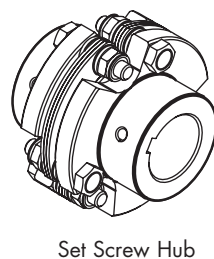
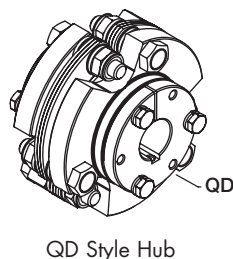
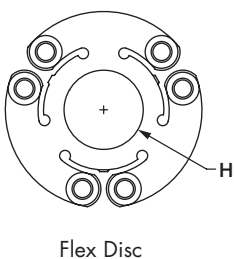

The A1C Aluminum hub version of our Single Flex Composite Disc Coupling features low weight and inertia, making it an excellent choice for servo motor applications. The unique hub design delivers flexibility making it a great fit for applications requiring high precision, high performance, and durability.

The integrated clamping hub design of the A1C Hub style allows for a wider range of shaft bores and higher shaft clamping forces while maintaining precise, high-performance specifications and a compact size to fit into many applications.

- Zero Backlash
- Torsionally Stiff
- Excellent for Reversing Loads
- Smooth Operation at High Speeds
- Maintenance-Free
- Misalignment Capacity
- Compact



Available with or without keyway on clamp style hubs

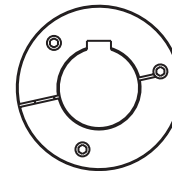

Note: Typical keyway placement

Performance Information

	Continuous Rated Torque	Peak Rated Torque	Torsional Stiffness	Maximum Speed	Misalignments			Unit Weight at		Inertia at	
	in-lbs (Nm)	in-lbs (Nm)	in-lbs/deg. (Nm/Rad)	(RPM)	Angular Degrees	Parallel Inch (mm)	Axial Inch (mm)	Max Bore Lb (kg)	Min Bore Lb (kg)	Max Bore lb-in ² (kg-cm ²)	Min Bore lb-in ² (kg-cm ²)
6A18-A1C	180 (20)	360 (40)	1,800 (11,650)	15,000	2	0.004 (0.10)	0.03 (0.8)	0.44 (0.20)	0.57 (0.26)	0.30 (0.88)	0.32 (0.95)
6A22-A1C	270 (30)	540 (60)	2,680 (17,352)	13,500	2	0.006 (0.15)	0.036 (0.9)	0.73 (0.33)	0.90 (0.41)	0.65 (1.9)	0.72 (2.1)
6A26-A1C	475 (53)	950 (106)	3,100 (20,100)	11,500	2	0.008 (0.20)	0.043 (1.1)	1.01 (0.46)	1.32 (0.60)	1.20 (3.5)	1.26 (3.7)
6A30-A1C	800 (90)	1,600 (180)	6,638 (42,976)	9,500	2	0.010 (0.25)	0.050 (1.3)	1.68 (0.76)	2.07 (0.94)	2.67 (7.8)	2.80 (8.2)
6A37-A1C	1,600 (181)	3,200 (362)	10,374 (67,167)	8,000	2	0.013 (0.33)	0.070 (1.8)	3.51 (1.59)	4.50 (2.04)	8.65 (25.3)	9.26 (27.1)
6A45-A1C	2,500 (282)	5,000 (564)	19,138 (123,909)	6,700	2	0.015 (0.38)	0.090 (2.3)	6.61 (3.00)	8.60 (3.90)	24.5 (71.6)	26.4 (77.1)

- Consult factory for speeds higher than those listed and balancing requirements, if necessary.
- Consult factory if higher torque and higher torsional stiffness couplings are required.

Dimensional Information

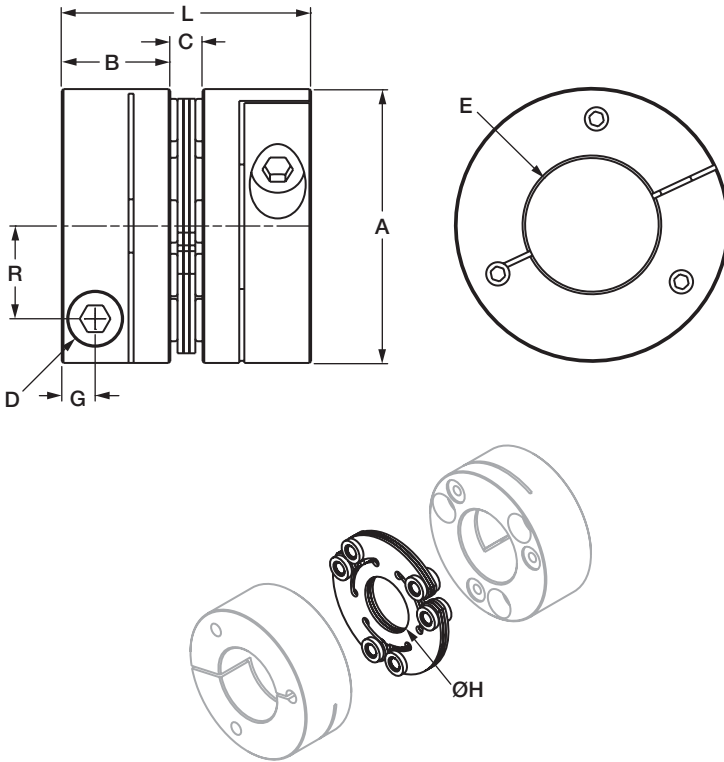

	A	B	C	E Bore		G	H	L	R	D
				Min	Max					
	Inch (mm)	Inch (mm)	Inch (mm)	Inch (mm)	Inch (mm)	Inch (mm)	Inch (mm)	Inch (mm)	Inch (mm)	
6A18-A1C	2.09 (53)	0.89 (22.5)	0.22 (5.49)	0.375 (8)	1.000 (26)	0.29 (7.2)	0.79 (20.1)	1.99 (50.5)	0.71 (18.0)	M6
6A22-A1C	2.44 (62)	1.02 (26)	0.23 (5.74)	0.500 (12)	1.188 (31)	0.29 (7.2)	0.98 (24.9)	2.27 (57.7)	0.87 (22.0)	M6
6A26-A1C	2.74 (69.5)	1.16 (29.5)	0.25 (6.25)	0.563 (14)	1.375 (35)	0.36 (9.1)	1.00 (25.4)	2.57 (65.2)	0.95 (24.0)	M8
6A30-A1C	3.23 (82)	1.28 (32.5)	0.38 (9.65)	0.688 (16)	1.500 (40)	0.39 (10.0)	1.21 (31)	2.94 (74.7)	1.09 (27.8)	M10
6A37-A1C	3.98 (101)	1.81 (46)	0.44 (11.23)	0.750 (18)	2.000 (51)	0.50 (12.7)	1.51 (38)	4.06 (103.2)	1.42 (36.0)	M12
6A45-A1C	4.84 (123)	2.36 (60)	0.50 (12.75)	1.000 (24)	2.500 (65)	0.67 (16.9)	1.81 (46)	5.23 (132.8)	1.71 (43.5)	M16

Bore Size (Inch)

Model	3/8"	7/16"	1/2"	9/16"	5/8"	11/16"	3/4"	13/16"	7/8"	15/16"	1"	1-1/16"	1-1/8"	1-3/16"	1-1/4"	1-5/16"	1-3/8"	1-7/16"
6A18-A1C	●	●	●	●	●	●	●	●	●	●	●							
6A22-A1C			●	●	●	●	●	●	●	●	●	●	●	●				
6A26-A1C				●	●	●	●	●	●	●	●	●	●	●	●	●	●	
6A30-A1C						●	●	●	●	●	●	●	●	●	●	●	●	●
6A37-A1C							●	●	●	●	●	●	●	●	●	●	●	●
6A45-A1C											●	●	●	●	●	●	●	●

Model	1-1/2"	1-9/16"	1-5/8"	1-11/16"	1-3/4"	1-13/16"	1-7/8"	1-15/16"	2"	2-1/16"	2-1/8"	2-3/16"	2-1/4"	2-5/16"	2-3/8"	2-7/16"	2-1/2"
6A18-A1C																	
6A22-A1C																	
6A26-A1C																	
6A30-A1C	●																
6A37-A1C	●	●	●	●	●	●	●	●	●								
6A45-A1C	●	●	●	●	●	●	●	●	●	●	●	●	●	●	●	●	●

Bore Size (Metric)

Model	8	9	10	11	12	13	14	15	16	17	18	19	20	22	24	25	26	28	30	32	35	38	40	42	45	48	50	52	55	58	60	62	65
6A18-A1C	●	●	●	●	●	●	●	●	●	●	●	●	●	●	●	●	●																
6A22-A1C			●	●	●	●	●	●	●	●	●	●	●	●	●	●	●	●	●	●	●	●	●	●	●	●	●	●	●	●	●	●	
6A26-A1C				●	●	●	●	●	●	●	●	●	●	●	●	●	●	●	●	●	●	●	●	●	●	●	●	●	●	●	●	●	
6A30-A1C							●	●	●	●	●	●	●	●	●	●	●	●	●	●	●	●	●	●	●	●	●	●	●	●	●	●	
6A37-A1C											●	●	●	●	●	●	●	●	●	●	●	●	●	●	●	●	●	●	●	●	●	●	
6A45-A1C														●	●	●	●	●	●	●	●	●	●	●	●	●	●	●	●	●	●	●	

●: The coupling will transmit full peak torque on a shaft without a keyway. Please contact the factory for additional bores.

The AC Aluminum hub version of our standard Single Flex Composite Disc Coupling features low weight and inertia, making it an excellent choice for servo motor applications. The unique design delivers two features that are not often found in a precision coupling. High torsional stiffness and high durability!

The compact size, low inertia, and clamping system enable this coupling to fit into many applications.

- Zero Backlash
- Torsionally Stiff
- Excellent for Reversing Loads
- Smooth Operation at High Speeds
- Misalignment Capacity
- Compact

- Consult factory for speeds higher than those listed and balancing requirements, if necessary.
- Consult factory for higher torque and higher torsional stiffness couplings.



Available with or without keyway on clamp style hubs

Performance Information

	Continuous Rated Torque	Peak Rated Torque	Torsional Stiffness	Maximum Speed Clamp Style Hub	Misalignments			Clamp Hub			
					Angular	Parallel	Axial	Unit Weight		Unit Inertia	
								at Max Bore	at 1/2 Max Bore	at Max Bore	at 1/2 Max Bore
	in-lbs (Nm)	in-lbs (Nm)	in-lbs/deg. (Nm/Rad)	(RPM)	Degrees	Inch (mm)	Inch (mm)	Lb (kg)	Lb (kg)	lb-in ² (kg-cm ²)	lb-in ² (kg-cm ²)
6A18-AC	180 (20)	360 (40)	1,800 (11,650)	15,000	3	0.004 (0.10)	0.030 (0.8)	0.32 (0.15)	0.31 (0.14)	0.15 (0.43)	0.13 (0.37)
6A22-AC	270 (30)	540 (60)	2,680 (17,352)	13,500	3	0.006 (0.15)	0.036 (0.9)	0.67 (0.30)	0.51 (0.23)	0.50 (1.45)	0.31 (0.90)
6A26-AC	475 (53)	950 (106)	3,100 (20,100)	11,500	3	0.008 (0.20)	0.043 (1.0)	0.77 (0.35)	0.66 (0.30)	0.68 (1.98)	0.45 (1.32)
6A30-AC	800 (90)	1,600 (180)	6,638 (42,976)	9,500	3	0.010 (0.3)	0.050 (1.3)	1.46 (0.66)	1.03 (0.47)	1.78 (5.21)	1.04 (3.04)
6A37-AC	1,600 (181)	3,200 (362)	10,374 (67,167)	8,000	3	0.013 (0.3)	0.070 (1.8)	2.58 (1.17)	1.74 (0.79)	5.17 (15.1)	2.82 (8.26)
6A45-AC	2,500 (282)	5,000 (564)	19,138 (123,909)	6,700	3	0.015 (0.4)	0.090 (2.3)	4.50 (2.04)	3.23 (1.46)	10.0 (29.3)	7.26 (21.2)
6A52-AC	3,560 (402)	7,120 (804)	26,049 (168,656)	5,800	3	0.018 (0.5)	0.110 (2.8)	6.07 (2.75)	5.01 (2.27)	18.9 (55.2)	14.8 (43.4)
6A60-AC	6,350 (718)	12,700 (1,436)	41,485 (268,595)	5,200	3	0.020 (0.5)	0.130 (3.3)	9.74 (4.42)	7.64 (3.46)	40.3 (118)	28.3 (82.7)

Clamp Style Hub

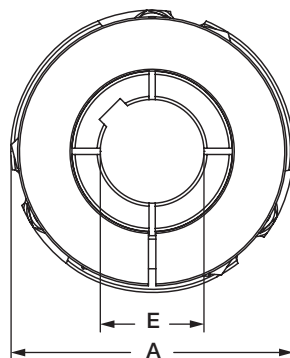
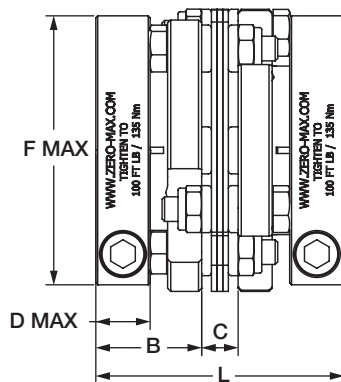

Dimensional Information

	A	B	C	D	Max Bore		F	H	L
					E				
					w/kwy	w/o kwy			
	Inch (mm)	Inch (mm)	Inch (mm)	Inch (mm)	Inch (mm)	Inch (mm)	Inch (mm)	Inch (mm)	Inch (mm)
6A18-AC	1.85 (47.0)	0.81 (20.6)	0.28 (7.1)	0.472 (12)	0.625 (16)	0.813 (21)	1.77 (45)	0.79 (20.1)	1.88 (47.8)
6A22-AC	2.25 (57.2)	1.00 (25.4)	0.31 (7.9)	0.551 (14)	0.750 (20)	0.938 (25)	2.21 (56)	0.98 (24.9)	2.31 (58.7)
6A26-AC	2.60 (66.0)	1.06 (26.9)	0.31 (7.9)	0.551 (14)	1.000 (24)	1.188 (30)	2.36 (60)	1.00 (25.4)	2.43 (61.7)
6A30-AC	3.00 (76.2)	1.25 (31.8)	0.46 (11.7)	0.709 (18)	1.125 (30)	1.375 (35)	2.92 (74)	1.21 (31)	2.96 (75.2)
6A37-AC	3.75 (95.3)	1.44 (36.6)	0.52 (13.2)	0.748 (19)	1.500 (40)	1.875 (48)	3.71 (94)	1.51 (38)	3.40 (86.4)
6A45-AC	4.50 (114.3)	1.69 (42.9)	0.58 (14.7)	0.866 (22)	1.750 (45)	2.250 (55)	4.29 (109)	1.81 (46)	3.96 (100.6)
6A52-AC	5.25 (133.4)	1.94 (49.3)	0.65 (16.5)	0.984 (25)	2.250 (60)	2.625 (65)	4.92 (125)	2.11 (54)	4.52 (114.8)
6A60-AC	6.00 (152.4)	2.44 (62.0)	0.77 (19.6)	1.339 (34)	2.625 (70)	3.000 (75)	5.71 (145)	2.42 (61)	5.64 (143.3)

Performance Note: The torque capacity of keyless clamped hubs is governed by many factors, including shaft/hub bore diameter, clamp size, and other installation variables. Keyless coupling hubs with smaller bore sizes (approximately less than one-half the maximum bore listed) may not transmit the full torque rating of the coupling. Consult factory for further detail if your application is of high torque/small shaft variety. The A1C Aluminum Hub Style can also be considered in these applications.

The Single Flex Composite Disc Stainless Steel coupling is an excellent choice for zero backlash applications that require stainless steel. The hubs and hardware are made from 300 Series stainless steel and the Composite Disc material is highly resistant to many harsh chemicals.

If your needs require a size of coupling that is not shown below, please contact Zero-Max.



Performance Information

- Consult factory for speeds higher than those listed and balancing requirements, if necessary.
- Consult factory for higher torque and higher torsional stiffness couplings.

	Continuous Rated Torque	Peak Rated Torque	Torsional Stiffness	Maximum Speed		Misalignments			A Hub		Clamp Hub	
				A & B Hub	Clamp Style Hub	Angular	Parallel	Axial	Unit Weight at Max Bore	Unit Inertia at Max Bore	Unit Weight at Max Bore	Unit Inertia at Max Bore
	in-lbs (Nm)	in-lbs (Nm)	in-lbs/deg. (Nm/Rad)	(RPM)	(RPM)	Degrees	Inch (mm)	Inch (mm)	Lb (kg)	lb-in ² (kg-cm ²)	Lb (kg)	lb-in ² (kg-cm ²)
6A30-SS 6A30C-SS	800 (90)	1,600 (181)	6,638 (42,976)	9,000	8,000	3	0.010 (0.3)	0.050 (1.3)	2.0 (0.9)	1.88 (5.50)	2.88 (1.31)	3.11 (9.11)
6A37-SS 6A37C-SS	1,600 (181)	3,200 (362)	10,374 (67,167)	7,400	6,700	3	0.013 (0.3)	0.070 (1.8)	3.6 (1.6)	5.57 (16.3)	6.04 (2.74)	9.62 (28.1)
6A45-SS 6A45C-SS	2,500 (282)	5,000 (564)	19,138 (123,909)	6,100	5,600	3	0.015 (0.4)	0.090 (2.3)	6.4 (2.9)	14.6 (42.7)	7.65 (3.47)	18.0 (52.6)
6A52-SS 6A52C-SS	3,560 (402)	7,120 (804)	26,049 (168,656)	5,200	4,800	3	0.018 (0.5)	0.110 (2.8)	10.5 (4.8)	32.4 (94.8)	11.93 (5.41)	38.9 (114)

Clamp Style Hub

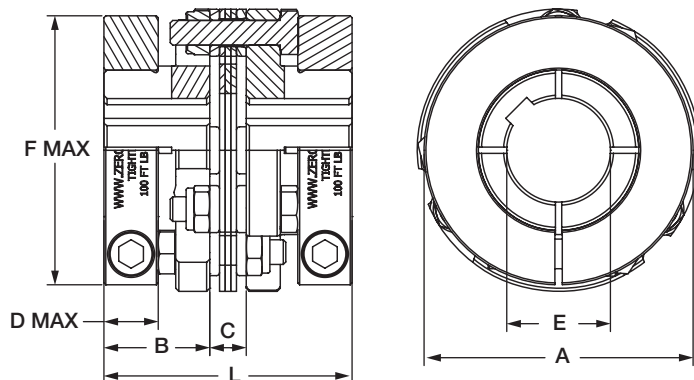

Dimensional Information

	A	B	C	D	Max Bore		F	H	L
					E				
	Inch (mm)	Inch (mm)	Inch (mm)	Inch (mm)	Inch (mm)	Inch (mm)	Inch (mm)	Inch (mm)	Inch (mm)
6A30C-SS	3.00 (76.2)	1.25 (31.8)	0.46 (11.7)	0.69 (17.5)	1.125 (28)	1.375 (35)	2.63 (66.8)	1.21 (31)	2.96 (75.2)
6A37C-SS	3.75 (95.3)	1.44 (36.6)	0.52 (13.2)	0.75 (19.1)	1.500 (40)	1.875 (48)	3.25 (82.6)	1.51 (38)	3.40 (86.4)
6A45C-SS	4.50 (114.3)	1.69 (42.9)	0.58 (14.7)	0.75 (19.1)	1.625 (42)	2.000 (50)	3.50 (88.9)	1.81 (46)	3.96 (100.6)
6A52C-SS	5.25 (133.4)	1.94 (49.3)	0.65 (16.5)	0.88 (22.4)	2.125 (55)	2.625 (65)	4.25 (108.0)	2.11 (54)	4.52 (114.8)

Performance Note: The torque capacity of keyless clamped hubs is governed by many factors, including shaft/hub bore diameter, clamp size, and other installation variables. Keyless coupling hubs with smaller bore sizes (approximately less than one-half the maximum bore listed) may not transmit the full torque rating of the coupling. Consult factory for further detail if your application is of high torque/small shaft variety.

Set Screw Style Hub

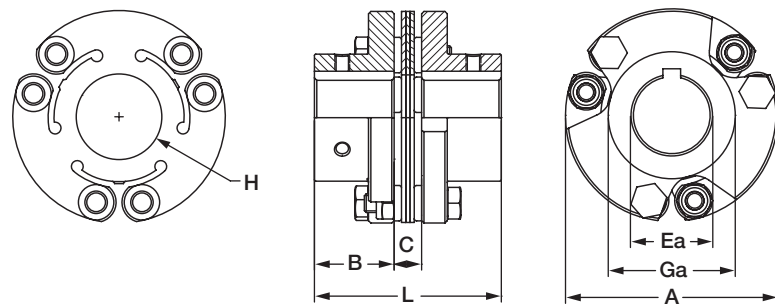

Dimensional Information

	A	B	C	Max Bore	Ga	H	L	X*
				Ea				
	Inch (mm)	Inch (mm)	Inch (mm)	Inch (mm)	Inch (mm)	Inch (mm)	Inch (mm)	Inch (mm)
6A30-SS	3.00 (76.2)	1.25 (31.8)	0.46 (11.7)	1.000 (25)	1.71 (43)	1.21 (31)	2.96 (75)	0.39 (9.9)
6A37-SS	3.75 (95.3)	1.44 (36.5)	0.52 (13.3)	1.250 (32)	2.19 (56)	1.51 (38)	3.40 (86)	0.68 (17.3)
6A45-SS	4.50 (114)	1.69 (42.9)	0.58 (14.8)	1.625 (42)	2.69 (68)	1.81 (46)	3.96 (101)	0.91 (23.1)
6A52-SS	5.25 (133)	1.94 (49.2)	0.65 (16.4)	1.875 (45)	3.31 (84)	2.11 (54)	4.52 (115)	0.73 (18.5)

* "X" dimension is the minimum bolt travel required beyond the hub to disassemble the disc pack from the hubs.

The Double Flex Composite Disc Coupling is ideal for precision applications that require more misalignment capacity than our Single Flex design. The coupling's large misalignment capacity, high torsional stiffness, and overall high performance specifications make this coupling a great choice for a wide variety of applications.



Available with or without keyway on clamp style hubs

- Zero Backlash
- Torsionally Stiff
- Excellent for Reversing Loads
- Smooth Operation at High Speeds
- High Misalignment Capacity
- Very Low Reaction Loads from Misalignment

Performance Information

	Continuous Rated Torque	Peak Rated Torque	Torsional Stiffness	Maximum Speed		Misalignments			A Hub		B Hub		Clamp Hub		QD Hubs
	in-lbs (Nm)	in-lbs (Nm)	in-lbs/deg. (Nm/Rad)	A & B Hub (RPM)	Clamp Style Hub (RPM)	Angular (Degrees)	Parallel (Inch (mm))	Axial (Inch (mm))	Unit Weight at Max Bore (Lb (kg))	Unit Inertia at Max Bore (lb-in ² (kg-cm ²))	Unit Weight at Max Bore (Lb (kg))	Unit Inertia at Max Bore (lb-in ² (kg-cm ²))	Unit Weight at Max Bore (Lb (kg))	Unit Inertia at Max Bore (lb-in ² (kg-cm ²))	Unit Weight w/ Bushing (Lb (kg))
6P18 6P18C	180 (20)	360 (40)	850 (5,500)	14,000	12,000	3	0.022 (0.56)	0.060 (1.5)	0.47 (0.21)	0.19 (0.56)	-	-	0.93 (0.42)	0.40 (1.17)	-
6P22 6P22C	270 (30)	540 (60)	1,310 (8,482)	12,000	11,000	3	0.026 (0.66)	0.072 (1.8)	1.10 (0.50)	0.66 (1.94)	1.18 (0.54)	0.82 (2.41)	1.79 (0.81)	1.25 (3.65)	-
6P26 6P26C	475 (53)	950 (106)	1,500 (9,712)	10,500	9,500	3	0.030 (0.76)	0.086 (2.2)	1.66 (0.75)	1.19 (3.47)	1.66 (0.75)	1.46 (4.28)	2.12 (0.96)	1.82 (5.31)	-
6P30 6P30C	800 (90)	1,600 (181)	3,231 (20,923)	9,000	8,000	3	0.039 (1.0)	0.100 (2.5)	2.5 (1.1)	2.49 (7.30)	3.0 (1.3)	3.49 (10.2)	4.01 (1.82)	4.70 (13.8)	-
6P37 6P37C 6P37QD	1,600 (181)	3,200 (362)	5,051 (32,700)	7,400	6,700	3	0.049 (1.2)	0.140 (3.6)	4.5 (2.1)	7.45 (21.8)	5.1 (2.3)	9.77 (28.6)	6.25 (2.83)	13.6 (39.7)	4.0 (1.8)
6P45 6P45C 6P45QD	2,500 (282)	5,000 (564)	9,317 (60,324)	6,100	5,600	3	0.052 (1.3)	0.180 (4.6)	7.9 (3.6)	19.1 (55.9)	8.7 (4.0)	24.5 (71.7)	12.1 (5.5)	25.7 (75.0)	8.1 (3.7)
6P52 6P52C 6P52QD	3,560 (402)	7,120 (804)	12,682 (82,109)	5,100	4,800	3	0.062 (1.6)	0.220 (5.6)	12.8 (5.8)	41.6 (122)	13.7 (6.2)	52.5 (154)	16.9 (7.6)	62.3 (182)	13.9 (6.3)
6P60 6P60C 6P60QD	6,350 (718)	12,700 (1,436)	20,196 (130,763)	4,600	4,400	3	0.069 (1.8)	0.260 (6.6)	18.4 (8.4)	79.3 (232)	21.5 (9.8)	109 (319)	26.3 (11.9)	134 (393)	18.9 (8.6)
6P67 6P67C 6P67QD	10,300 (1,164)	20,600 (2,328)	30,159 (195,265)	4,300	4,100	3	0.076 (1.9)	0.300 (7.6)	26.2 (11.9)	141 (413)	30.7 (14.0)	193 (565)	39.2 (17.8)	235 (687)	24.7 (11.2)
6P77 6P77QD	15,600 (1,763)	31,200 (3,526)	45,815 (296,634)	3,300	-	3	0.089 (2.3)	0.320 (8.1)	38.5 (17.5)	273 (799)	45.8 (20.8)	381 (1,115)	-	-	36.8 (16.7)
6P90	25,000 (2,825)	50,000 (5,650)	78,213 (506,395)	2,800	-	3	0.101 (2.6)	0.360 (9.1)	61.4 (27.9)	596 (1,744)	74.1 (33.7)	857 (2,508)	-	-	-
6P105	34,900 (3,944)	69,800 (7,888)	118,889 (769,756)	2,500	-	3	0.126 (3.2)	0.420 (10.7)	101 (45.9)	1,362 (3,986)	118 (53.6)	1,888 (5,525)	-	-	-
6P120	47,200 (5,333)	94,400 (10,666)	159,730 (1,034,187)	2,100	-	3	0.137 (3.5)	0.500 (12.7)	150 (68.2)	2,600 (7,609)	167 (76.0)	3,646 (10,670)	-	-	-

- Consult factory for speeds higher than those listed and balancing requirements, if necessary.
- Consult factory for higher torque and higher torsional stiffness couplings.

Clamp Style Hub

Dimensional Information

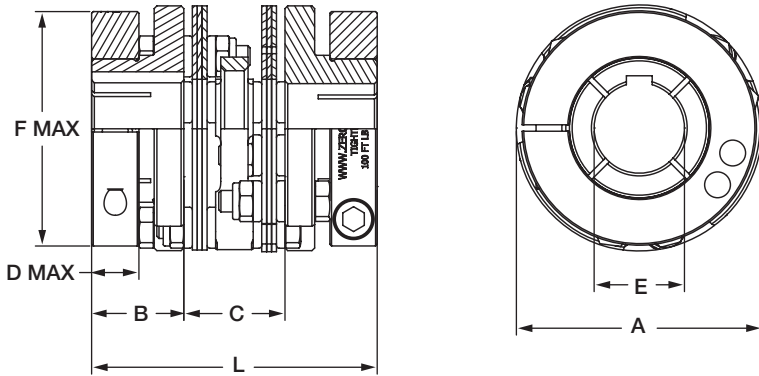

	A	B	C	D	Max Bore		F	H	L
					E w/kwy	E w/o kwy			
	Inch (mm)	Inch (mm)	Inch (mm)	Inch (mm)	Inch (mm)	Inch (mm)	Inch (mm)	Inch (mm)	Inch (mm)
6P18C	1.85 (47.0)	0.81 (20.6)	0.80 (20.3)	0.472 (12)	0.625 (16)	0.813 (21)	1.77 (45)	0.79 (20.1)	2.42 (61.5)
6P22C	2.25 (57.2)	1.00 (25.4)	0.96 (24.4)	0.551 (14)	0.750 (20)	0.938 (25)	2.21 (56)	0.98 (24.9)	2.96 (75.2)
6P26C	2.60 (66.0)	1.06 (26.9)	1.04 (26.4)	0.551 (14)	1.000 (24)	1.188 (30)	2.36 (60)	1.00 (25.4)	3.16 (80.3)
6P30C	3.00 (76.2)	1.25 (31.8)	1.42 (36.1)	0.709 (18)	1.125 (30)	1.375 (35)	2.92 (74)	1.21 (31)	3.92 (99.6)
6P37C	3.75 (95.3)	1.44 (36.6)	1.67 (42.4)	0.748 (19)	1.500 (40)	1.875 (48)	3.71 (94)	1.51 (38)	4.55 (115.6)
6P45C	4.50 (114.3)	1.69 (42.9)	1.85 (47.0)	0.866 (22)	1.750 (45)	2.250 (55)	4.29 (109)	1.81 (46)	5.23 (132.8)
6P52C	5.25 (133.4)	1.94 (49.3)	2.11 (53.6)	0.984 (25)	2.250 (60)	2.625 (65)	4.92 (125)	2.11 (54)	5.98 (151.9)
6P60C	6.00 (152.4)	2.44 (62.0)	2.41 (61.2)	1.339 (34)	2.625 (70)	3.000 (75)	5.71 (145)	2.42 (61)	7.29 (185.2)
6P67C	6.75 (171.5)	2.75 (69.9)	2.70 (68.6)	1.339 (34)	2.875 (80)	3.500 (90)	6.50 (165)	2.72 (69)	8.20 (208.3)

Performance Note: The torque capacity of keyless clamped hubs is governed by many factors, including shaft/hub bore diameter, clamp size, and other installation variables. Keyless coupling hubs with smaller bore sizes (approximately less than one-half the maximum bore listed) may not transmit the full torque rating of the coupling. Consult factory for more detail if your application is of high torque/small shaft variety.

Dimensional Information

Set Screw Hub

QD Style Hub

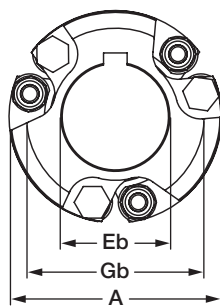
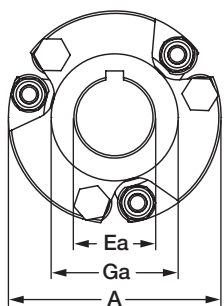
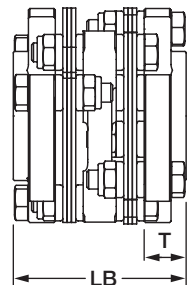
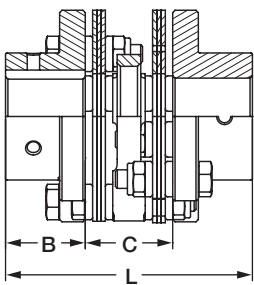

A Hub

B Hub

	A	B	C	Max Bore	Max Bore	Ga	Gb	H	L	X*	Y*	QD Only		
				Ea A Hub	Eb B Hub							LB	T	QD**
	Inch (mm)	Inch (mm)	Inch (mm)	Inch (mm)	Inch (mm)	Inch (mm)	Inch (mm)	Inch (mm)	Inch (mm)	Inch (mm)	Inch (mm)	Inch (mm)	Inch (mm)	Type
6P18	1.85 (47.0)	0.625 (15.9)	0.803 (20.4)	0.625 (16)	-	1.125 (28.6)	-	0.79 (20.1)	2.05 (52.1)	-	0.48 (12.2)	-	-	-
6P22	2.25 (57.2)	0.938 (23.8)	0.956 (24.3)	0.625 (16)	1.000 (26)	1.219 (31)	1.88 (47.6)	0.98 (24.9)	2.83 (71.9)	0.51 (13)	0.64 (16.3)	-	-	-
6P26	2.59 (65.9)	1.06 (27)	1.03 (26.3)	0.750 (19)	1.250 (32)	1.502 (38.2)	2.16 (54.8)	1.00 (25.4)	3.16 (80.2)	0.39 (9.9)	0.47 (12)	-	-	-
6P30	3.00 (76.2)	1.25 (31.8)	1.42 (36.1)	1.000 (25)	1.375 (35)	1.71 (43)	2.50 (64)	1.21 (31)	3.92 (100)	0.39 (9.9)	0.68 (17.3)	-	-	-
6P37 6P37QD	3.75 (95.3)	1.44 (36.5)	1.67 (42.4)	1.250 (32)	1.813 (46)	2.19 (56)	3.13 (79)	1.51 (38)	4.55 (115)	0.68 (17.3)	0.95 (24.1)	2.93 (75)	0.63 (16)	JA**
6P45 6P45QD	4.50 (114)	1.69 (42.9)	1.85 (47.0)	1.625 (42)	2.250 (60)	2.69 (68)	3.75 (95)	1.81 (46)	5.23 (133)	0.91 (23.1)	1.35 (34.3)	3.61 (92)	0.88 (22.4)	SH**
6P52 6P52QD	5.25 (133)	1.94 (49.2)	2.11 (53.5)	1.875 (45)	2.625 (66)	3.31 (84)	4.38 (111)	2.11 (54)	5.98 (152)	0.73 (18.5)	1.10 (27.9)	4.87 (124)	1.38 (35.1)	SD**
6P60 6P60QD	6.00 (152)	2.44 (61.9)	2.41 (61.2)	2.250 (60)	3.000 (76)	3.67 (93)	5.00 (127)	2.42 (61)	7.29 (185)	0.69 (17.5)	1.42 (36.1)	5.17 (131)	1.38 (35.1)	SD**
6P67 6P67QD	6.75 (171)	2.75 (69.9)	2.70 (68.7)	2.625 (65)	3.375 (85)	4.29 (108)	5.63 (143)	2.72 (69)	8.20 (208)	0.41 (10.4)	1.11 (28.2)	5.46 (139)	1.38 (35.1)	SK**
6P77 6P77QD	7.75 (197)	3.13 (79.4)	3.15 (80.1)	2.875 (75)	3.875 (100)	4.61 (117)	6.46 (164)	3.13 (79)	9.40 (239)	0.89 (22.6)	1.40 (35.6)	6.15 (156)	1.38 (35.1)	SF**
6P90	9.00 (229)	3.75 (95.3)	3.58 (91.0)	3.000 (75)	4.500 (120)	5.38 (137)	7.50 (190)	3.62 (92)	11.08 (281)	1.39 (35.3)	1.47 (37.3)	-	-	-
6P105	10.50 (267)	4.25 (108)	4.42 (112)	3.750 (95)	5.125 (130)	6.11 (155)	8.75 (222)	4.23 (107)	12.92 (328)	1.92 (48.8)	2.64 (67.1)	-	-	-
6P120	12.00 (305)	4.75 (121)	4.82 (123)	4.250 (110)	6.000 (152)	7.34 (186)	10.00 (254)	4.83 (123)	14.32 (364)	1.48 (37.6)	2.14 (54.4)	-	-	-

*"X" and "Y" dimensions are the minimum bolt travel required beyond the hub to disassemble the disc packs and intermediate member, respectively, from the hubs.

** QD Bushings not included with coupling. Customer supplied. Customer must verify bushing torque value.

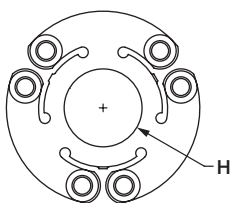

Flex Disc

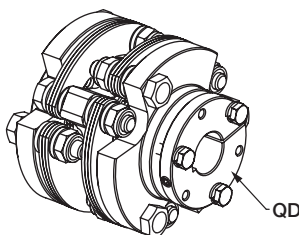

QD Style Hub

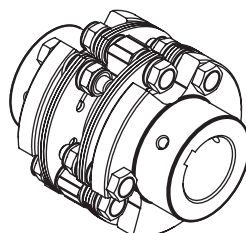

Set Screw Hub



QD Style Hub



Set Screw Hub

The A1C Aluminum hub version of our Double Flex Composite Disc Coupling is ideal for applications that require more misalignment capacity than our Single Flex design. This series also features low weight and inertia aluminum hubs making it an excellent choice for servo motor applications requiring high precision, high performance, and durability.

The integrated clamping hub design of the A1C Hub style allows for a wider range of shaft bores and higher shaft clamping forces. This coupling's large misalignment capacity, high torsional stiffness, and overall performance specifications make it a great fit in many applications.

- Zero Backlash
- Torsionally Stiff
- Excellent for Reversing Loads
- Smooth Operation at High Speeds
- Maintenance-Free
- High Misalignment Capacity
- Very Low Reaction Loads from Misalignment



Available with or without keyway on clamp style hubs

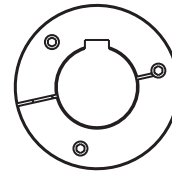

Note: Typical keyway placement

Performance Information

	Continuous Rated Torque	Peak Rated Torque	Torsional Stiffness	Maximum Speed	Misalignments			Unit Weight at		Inertia at	
	in-lbs (Nm)	in-lbs (Nm)	in-lbs/deg. (Nm/Rad)	(RPM)	Angular Degrees	Parallel Inch (mm)	Axial Inch (mm)	Max Bore Lb (kg)	Min Bore Lb (kg)	Max Bore lb-in ² (kg-cm ²)	Min Bore lb-in ² (kg-cm ²)
6P18-A1C	180 (20)	360 (40)	850 (5,500)	15,000	2	0.017 (0.44)	0.063 (1.6)	0.55 (0.25)	0.66 (0.30)	1.03 (3.0)	0.38 (1.1)
6P22-A1C	270 (30)	540 (60)	1,310 (8,482)	13,500	2	0.023 (0.58)	0.071 (1.8)	0.86 (0.39)	1.04 (0.47)	0.75 (2.2)	0.82 (2.4)
6P26-A1C	475 (53)	950 (106)	1,500 (9,712)	11,500	2	0.022 (0.55)	0.087 (2.2)	1.19 (0.54)	1.43 (0.65)	1.40 (4.1)	1.47 (4.3)
6P30-A1C	800 (90)	1,600 (180)	3,231 (20,923)	9,500	2	0.033 (0.85)	0.102 (2.6)	2.14 (0.97)	2.51 (1.14)	3.42 (10.0)	3.76 (11.0)
6P37-A1C	1,600 (181)	3,200 (362)	5,051 (32,700)	7,900	2	0.039 (1.00)	0.142 (3.6)	4.48 (2.03)	5.36 (2.43)	10.8 (31.7)	11.3 (33.1)
6P45-A1C	2,500 (282)	5,000 (564)	9,317 (60,324)	6,700	2	0.049 (1.24)	0.181 (4.6)	8.16 (3.70)	10.1 (4.60)	29.1 (85.0)	30.8 (90.0)

- Consult factory for speeds higher than those listed and balancing requirements, if necessary.
- Consult factory for higher torque and higher torsional stiffness couplings.

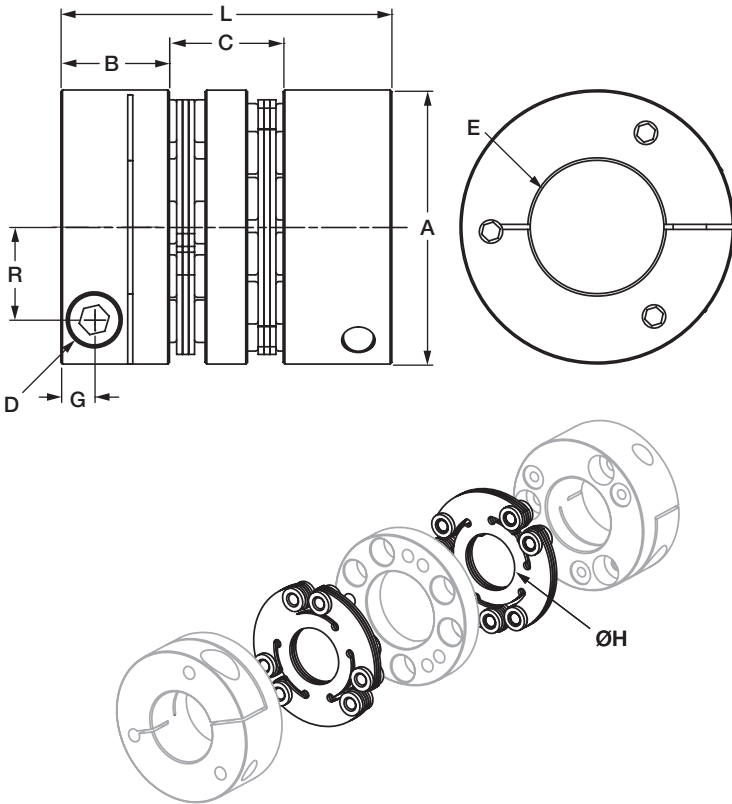

Dimensional Information

	A	B	C	E Bore		G	H	L	R	D
				Min	Max					
	Inch (mm)	Inch (mm)	Inch (mm)	Inch (mm)	Inch (mm)	Inch (mm)	Inch (mm)	Inch (mm)	Inch (mm)	
6P18-A1C	2.09 (53)	0.89 (22.5)	0.71 (18)	0.375 (8)	1.000 (26)	0.29 (7.2)	0.79 (20.1)	2.48 (63)	0.71 (18.0)	M6
6P22-A1C	2.44 (62)	1.02 (26)	0.91 (23)	0.500 (12)	1.188 (31)	0.29 (7.2)	0.98 (24.9)	2.95 (75)	0.87 (22.0)	M6
6P26-A1C	2.74 (69.5)	1.16 (29.5)	0.87 (22)	0.563 (14)	1.375 (35)	0.36 (9.1)	1.00 (25.4)	3.19 (81)	0.95 (24.0)	M8
6P30-A1C	3.23 (82)	1.28 (32.5)	1.34 (34)	0.688 (16)	1.500 (40)	0.39 (10.0)	1.21 (31)	3.90 (99)	1.09 (27.8)	M10
6P37-A1C	3.98 (101)	1.81 (46)	1.65 (42)	0.750 (18)	2.000 (51)	0.50 (12.7)	1.51 (38)	5.28 (134)	1.42 (36.0)	M12
6P45-A1C	4.84 (123)	2.36 (60)	1.89 (48)	1.000 (24)	2.500 (65)	0.67 (16.9)	1.81 (46)	6.61 (168)	1.71 (43.5)	M16

Bore Size (Inch)

Model	3/8"	7/16"	1/2"	9/16"	5/8"	11/16"	3/4"	13/16"	7/8"	15/16"	1"	1-1/16"	1-1/8"	1-3/16"	1-1/4"	1-5/16"	1-3/8"	1-7/16"
6P18-A1C	●	●	●	●	●	●	●	●	●	●	●							
6P22-A1C			●	●	●	●	●	●	●	●	●	●	●	●				
6P26-A1C				●	●	●	●	●	●	●	●	●	●	●	●	●	●	
6P30-A1C						●	●	●	●	●	●	●	●	●	●	●	●	●
6P37-A1C							●	●	●	●	●	●	●	●	●	●	●	●
6P45-A1C											●	●	●	●	●	●	●	●

Model	1-1/2"	1-9/16"	1-5/8"	1-11/16"	1-3/4"	1-13/16"	1-7/8"	1-15/16"	2"	2-1/16"	2-1/8"	2-3/16"	2-1/4"	2-5/16"	2-3/8"	2-7/16"	2-1/2"
6P18-A1C																	
6P22-A1C																	
6P26-A1C																	
6P30-A1C	●																
6P37-A1C	●	●	●	●	●	●	●	●	●								
6P45-A1C	●	●	●	●	●	●	●	●	●	●	●	●	●	●	●	●	●

Bore Size (Metric)

Model	8	9	10	11	12	13	14	15	16	17	18	19	20	22	24	25	26	28	30	32	35	38	40	42	45	48	50	52	55	58	60	62	65
6P18-A1C	●	●	●	●	●	●	●	●	●	●	●	●	●	●	●	●																	
6P22-A1C			●	●	●	●	●	●	●	●	●	●	●	●	●	●	●	●	●	●	●												
6P26-A1C				●	●	●	●	●	●	●	●	●	●	●	●	●	●	●	●	●	●	●											
6P30-A1C							●	●	●	●	●	●	●	●	●	●	●	●	●	●	●	●	●	●	●	●	●	●	●	●	●	●	
6P37-A1C											●	●	●	●	●	●	●	●	●	●	●	●	●	●	●	●	●	●	●	●	●	●	
6P45-A1C																	●	●	●	●	●	●	●	●	●	●	●	●	●	●	●	●	●

●: The coupling will transmit full peak torque on a shaft without a keyway. Please contact the factory for additional bores.

The AC Aluminum hub version of our standard Double Flex Composite Disc Coupling is ideal for precision applications that require more misalignment capacity than our Single Flex design. The coupling's large misalignment capacity, high torsional stiffness, and overall high performance specifications make this coupling a great choice for a wide variety of applications. Aluminum hubs offer all this with low weight and inertia.

- Zero Backlash
- Torsionally Stiff
- Excellent for Reversing Loads
- High Misalignment Capacity
- Smooth Operation at High Speeds
- Very Low Reaction Loads from Misalignment



Available with or without keyway on clamp style hubs

Performance Information

	Continuous Rated Torque	Peak Rated Torque	Torsional Stiffness	Maximum Speed Clamp Style Hub (RPM)	Misalignments			Clamp Hub			
					Angular	Parallel	Axial	Unit Weight		Unit Inertia	
								at Max Bore	at 1/2 Max Bore	at Max Bore	at 1/2 Max Bore
in-lbs (Nm)	in-lbs (Nm)	in-lbs/deg. (Nm/Rad)	Degrees	Inch (mm)	Inch (mm)	Lb (kg)	Lb (kg)	lb-in ² (kg-cm ²)	lb-in ² (kg-cm ²)		
6P18-AC	180 (20)	360 (40)	850 (5,500)	15,000	3	0.022 (0.56)	0.060 (1.5)	0.43 (0.20)	0.43 (0.19)	0.20 (0.57)	0.18 (0.51)
6P22-AC	270 (30)	540 (60)	1,310 (8,482)	11,000	3	0.026 (0.66)	0.072 (1.8)	0.89 (0.40)	0.73 (0.33)	0.66 (1.94)	0.48 (1.39)
6P26-AC	475 (53)	950 (106)	1,500 (9,712)	9,500	3	0.030 (0.76)	0.086 (2.2)	1.06 (0.48)	0.95 (0.43)	0.93 (2.72)	0.70 (2.05)
6P30-AC	800 (90)	1,600 (181)	3,231 (20,923)	8,000	3	0.039 (1.0)	0.100 (2.5)	1.96 (0.89)	1.53 (0.69)	2.41 (7.05)	1.67 (4.88)
6P37-AC	1,600 (181)	3,200 (362)	5,051 (32,700)	6,700	3	0.049 (1.2)	0.140 (3.6)	3.53 (1.60)	2.69 (1.22)	7.07 (20.7)	4.72 (13.8)
6P45-AC	2,500 (282)	5,000 (564)	9,317 (60,324)	5,600	3	0.052 (1.3)	0.180 (4.6)	6.00 (2.72)	4.73 (2.15)	14.5 (42.3)	11.7 (34.3)
6P52-AC	3,560 (402)	7,120 (804)	12,682 (82,109)	4,800	3	0.062 (1.6)	0.220 (5.6)	8.28 (3.75)	7.22 (3.27)	28.1 (82.3)	24.1 (70.5)
6P60-AC	6,350 (718)	12,700 (1,436)	20,196 (130,763)	4,400	3	0.069 (1.8)	0.260 (6.6)	12.8 (5.8)	10.7 (4.9)	58.2 (170)	46.2 (135)

- Consult factory for speeds higher than those listed and balancing requirements, if necessary.
- Consult factory for higher torque and higher torsional stiffness couplings.

Clamp Style Hub

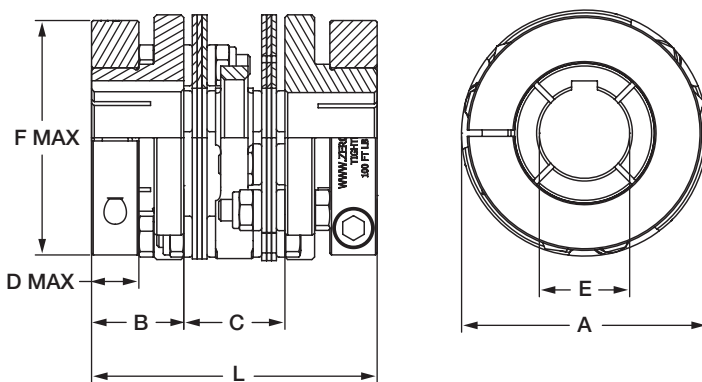

Performance Note: The torque capacity of keyless clamped hubs is governed by many factors, including shaft/hub bore diameter, clamp size, and other installation variables. Keyless coupling hubs with smaller bore sizes (approximately less than one-half the maximum bore listed) may not transmit the full torque rating of the coupling. Consult factory for more detail if your application is of high torque/small shaft variety. The A1C Aluminum hub style can also be considered in these applications.

Dimensional Information

	A	B	C	D	Max Bore		F	H	L
					E				
					w/kwy	w/o kwy			
Inch (mm)	Inch (mm)	Inch (mm)	Inch (mm)	Inch (mm)	Inch (mm)	Inch (mm)	Inch (mm)	Inch (mm)	
6P18-AC	1.85 (47.0)	0.81 (20.6)	0.80 (20.3)	0.472 (12)	0.625 (16)	0.813 (21)	1.77 (45)	0.79 (20.1)	2.42 (61.5)
6P22-AC	2.25 (57.2)	1.00 (25.4)	0.96 (24.4)	0.551 (14)	0.750 (20)	0.938 (25)	2.21 (56)	0.98 (24.9)	2.96 (75.2)
6P26-AC	2.60 (66.0)	1.06 (26.9)	1.04 (26.4)	0.551 (14)	1.000 (24)	1.188 (30)	2.36 (60)	1.00 (25.4)	3.16 (80.3)
6P30-AC	3.00 (76.2)	1.25 (31.8)	1.42 (36.1)	0.709 (18)	1.125 (30)	1.375 (35)	2.92 (74)	1.21 (31)	3.92 (99.6)
6P37-AC	3.75 (95.3)	1.44 (36.6)	1.67 (42.4)	0.748 (19)	1.500 (40)	1.875 (48)	3.71 (94)	1.51 (38)	4.55 (115.6)
6P45-AC	4.50 (114.3)	1.69 (42.9)	1.85 (47.0)	0.866 (22)	1.750 (45)	2.250 (55)	4.29 (109)	1.81 (46)	5.23 (132.8)
6P52-AC	5.25 (133.4)	1.94 (49.3)	2.11 (53.6)	0.984 (25)	2.250 (60)	2.625 (65)	4.92 (125)	2.11 (54)	5.98 (151.9)
6P60-AC	6.00 (152.4)	2.44 (62.0)	2.41 (61.2)	1.339 (34)	2.625 (70)	3.000 (75)	5.71 (145)	2.42 (61)	7.29 (185.2)

The Composite Disc Floating Shaft Coupling is zero backlash and torsionally stiff, yet provides superior misalignment capacity. Additionally, the patented Composite Disc provides excellent support for the floating shaft component with very low radial load on the connected equipment and bearings. Precision hardware and precise machining ensures smooth and accurate operation.

- Zero Backlash
- Torsionally Stiff
- Excellent for Reversing Loads
- Very Low Reaction Loads
- Available in Both Set Screw and Clamp Style Hubs
- Made to Exact Length Requirements



Available with or without keyway on clamp style hubs

Performance Information

	Continuous Rated Torque	Peak Rated Torque	Torsional Stiffness				Maximum Misalignments			A Hub		B Hub		Clamp Hub			Inertia adder per inch of DBSE (per meter of DBSE)	
			Baseline at 12" DBSE (300mm DBSE)	Factor Z	Factor Y	Factor Z1	Factor Y1	Angular	Parallel	Axial	Base Unit Wt. at 12" (300mm DBSE)	Base Unit Inertia at 12" DBSE (300mm DBSE)	Additional Weight for each hub	Additional Inertia for each hub	Additional Weight for each hub (maximum)	Additional Inertia for each hub (maximum)		Weight adder per inch of DBSE (per meter of DBSE)
			See Note 1					See Note 2	Inch/ inch of DBSE (mm/ meter of DBSE)		See Note 3	See Note 3						See Note 3
	in-lbs (Nm)	in-lbs (Nm)	in-lbs/deg. (Nm/Rad)	in-lbs/deg.	in-lbs/deg.	(Nm/Radian)	(Nm/Radian)	Degrees		Inch (mm)	Lb (kg)	lb-in ² (kg-cm ²)	Lb (kg)	lb-in ² (kg-cm ²)	Lb (kg)	lb-in ² (kg-cm ²)	lb/inch (kg/ meter)	lb-in ² /inch (kg-cm ² / meter)
6F22 6F22C	270 (30)	540 (60)	516 (3,379)	0.05	0.84	(0.338)	(138)	2.5	0.022 (22)	0.060 (1.5)	2.00 (0.9)	0.86 (2.52)	0.04 (0.02)	0.09 (0.2)	0.32 (0.14)	0.15 (0.4)	0.054 (0.97)	0.012 (1.37)
6F26 6F26C	475 (53)	950 (106)	857 (5,589)	0.09	2.09	(0.559)	(344)	2.5	0.022 (22)	0.080 (2.0)	3.29 (1.5)	1.90 (5.56)	0.20 (0.09)	0.14 (0.4)	0.40 (0.18)	0.33 (1.0)	0.086 (1.54)	0.029 (3.40)
6F30 6F30C	800 (90)	1,600 (180)	1,246 (8,157)	0.13	2.09	(0.816)	(344)	2.5	0.022 (22)	0.100 (2.5)	4.19 (1.9)	3.44 (10.1)	0.25 (0.1)	0.48 (1.4)	0.65 (0.3)	0.77 (2.3)	0.086 (1.54)	0.029 (3.40)
6F37 6F37C	1,600 (181)	3,200 (362)	3,754 (24,439)	0.38	13.05	(2.444)	(2,146)	3	0.026 (26)	0.14 (3.6)	8.30 (3.8)	11.8 (34.5)	0.30 (0.1)	1.2 (3.4)	1.01 (0.5)	1.9 (5.6)	0.208 (3.73)	0.184 (21.2)
6F45 6F45C	2,500 (282)	5,000 (564)	7,215 (46,963)	0.72	25.57	(4.696)	(4,205)	3	0.026 (26)	0.18 (4.6)	13.2 (6.0)	28.2 (82.4)	0.42 (0.2)	2.7 (7.9)	1.01 (0.5)	4.6 (13.4)	0.254 (4.54)	0.360 (41.6)
6F52 6F52C	3,560 (402)	7,120 (804)	9,921 (64,571)	0.99	35.72	(6.457)	(5,874)	3	0.026 (26)	0.22 (5.6)	20.9 (9.5)	61.1 (179)	0.45 (0.2)	5.4 (15.8)	3.7 (1.7)	13.3 (38.8)	0.292 (5.22)	0.504 (58.2)
6F60 6F60C	6,350 (718)	12,700 (1,436)	15,749 (102,533)	1.58	53.3	(10.253)	(8,765)	3	0.026 (26)	0.26 (6.6)	28.2 (12.8)	109 (320)	1.5 (0.7)	14.6 (42.8)	5.0 (2.3)	15.4 (45.0)	0.333 (5.97)	0.751 (86.8)
6F67 6F67C	10,300 (1,164)	20,600 (2,328)	24,219 (157,561)	2.42	93.98	(15.756)	(15,454)	3	0.026 (26)	0.30 (7.6)	39.7 (18.0)	201 (587)	2.3 (1.0)	25.8 (75.5)	5.6 (2.5)	18.0 (52.6)	0.403 (7.21)	1.33 (153)

Note: 1) For torsional stiffness (K, in.-lb./deg.) of units longer than 12", use the following formula, where L=(DBSE-12) : $K = \left[\frac{Z \times Y}{(L \times Z) + Y} \right] \times 10^4$

For torsional stiffness (K, Nm/Radian) of units longer than 300mm, use the following formula, where L=(DBSE-300) : $K = \left[\frac{Z1 \times Y1}{(L \times Z1) + Y1} \right] \times 10^4$

Note: 2) See page 17 regarding selection of coupling and misalignment capability.

Note: 3) For weight and inertia of units longer than 12"(300mm), subtract 12"(300mm) from the DBSE (dimension C) and multiply by weight/inertia adders listed above.

See the following page for maximum C Length and RPM data

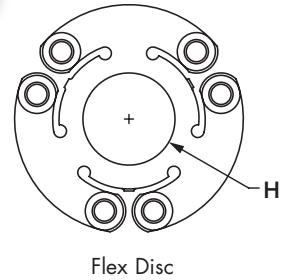
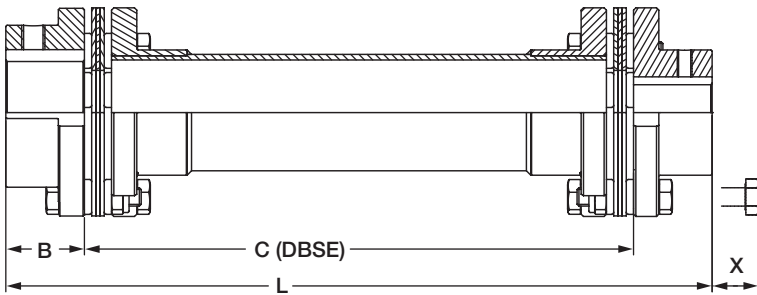

Set Screw Style Hubs

Clamp Style Hub

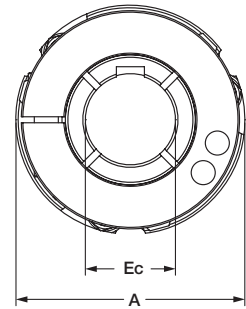
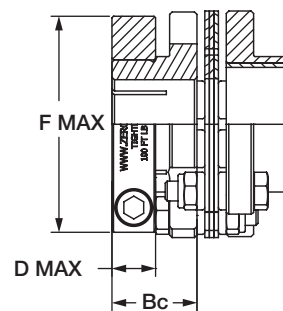
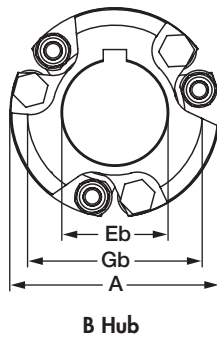
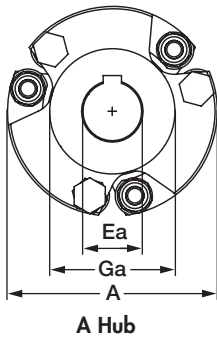

Dimensional Information

	Max Bore													
	A	B A & B Hub	Bc C Hub	D max. C Hub	F Max. C Hub	Set Screw Hub		Clamp Hubs		Ga A Hub	Gb B Hub	H	X*	C min.
						Ea A Hub	Eb B Hub	Ec C Hub w/kwy	Ec C Hub w/o kwy					
Inch (mm)	Inch (mm)	Inch (mm)	Inch (mm)	Inch (mm)	Inch (mm)	Inch (mm)	Inch (mm)	Inch (mm)	Inch (mm)	Inch (mm)	Inch (mm)	Inch (mm)	Inch (mm)	
6F22 6F22C	2.25 (57.2)	0.94 (23.8)	1.00 (25.4)	0.551 (14)	2.21 (56)	0.625 (16)	1.000 (26)	0.750 (20)	0.938 (25)	1.22 (31.0)	1.88 (47.6)	0.98 (24.9)	0.51 (13.0)	2.00 (50.8)
6F26 6F26C	2.59 (65.8)	1.06 (27.0)	1.06 (27.0)	0.551 (14)	2.36 (60)	0.750 (19)	1.250 (32)	1.000 (24)	1.188 (30)	1.50 (38.1)	2.16 (54.8)	1.00 (25.4)	0.39 (9.9)	2.38 (60.5)
6F30 6F30C	3.00 (76.2)	1.25 (31.8)	1.25 (31.8)	0.709 (18)	2.92 (74)	1.000 (25)	1.375 (35)	1.125 (30)	1.375 (35)	1.71 (43.4)	2.50 (63.5)	1.21 (31)	0.39 (9.9)	2.69 (68.3)
6F37 6F37C	3.75 (95.3)	1.44 (36.5)	1.44 (36.5)	0.748 (19)	3.71 (94)	1.250 (32)	1.813 (46)	1.500 (40)	1.875 (48)	2.19 (55.6)	3.13 (79.4)	1.51 (38)	0.68 (17.3)	3.44 (87.4)
6F45 6F45C	4.50 (114.3)	1.69 (42.9)	1.69 (42.9)	0.866 (22)	4.29 (109)	1.625 (42)	2.250 (60)	1.750 (45)	2.250 (55)	2.69 (68.3)	3.75 (95.3)	1.81 (46)	0.91 (23.1)	4.43 (113)
6F52 6F52C	5.25 (133.4)	1.94 (49.2)	1.94 (49.2)	0.984 (25)	4.92 (125)	1.875 (45)	2.625 (66)	2.250 (60)	2.625 (65)	3.31 (84.1)	4.38 (111.1)	2.11 (54)	0.73 (18.5)	5.19 (132)
6F60 6F60C	6.00 (152.4)	2.44 (61.9)	2.44 (61.9)	1.339 (34)	5.71 (145)	2.250 (60)	3.000 (76)	2.625 (70)	3.000 (75)	3.67 (93.2)	5.00 (127.0)	2.42 (61)	0.69 (17.5)	6.06 (154)
6F67 6F67C	6.75 (171.5)	2.75 (69.9)	2.75 (69.9)	1.339 (34)	6.50 (165)	2.625 (65)	3.375 (85)	2.875 (80)	3.500 (90)	4.29 (109.0)	5.63 (142.9)	2.72 (69)	0.41 (10.4)	6.62 (169)

- Dimension L is equal to (2x B) + C (C is the DBSE or span)
- Dimension C is always manufactured to application requirements
- * "X" dimension is minimum bolt travel required beyond the hub to disassemble disc packs from the hubs.

Performance Note: The torque capacity of keyless clamped hubs is governed by many factors, including shaft hub/bore diameter, clamp size, and other installation variables. Keyless coupling hubs with smaller bore sizes (approximately less than one-half the maximum bore listed) may not transmit the full torque rating of the coupling. Consult factory for further detail if your application is of high torque/small keyless shaft variety.

The table below shows lengths and speeds at which standard floating shaft couplings can operate while avoiding natural frequencies. Couplings at or near table values may require dynamic balancing. See below for balancing information. Should your application fall outside these parameters, consult the factory. Special construction of the disc pack or floating shaft can increase speeds and/or maximum lengths. Refer to coupling misalignment information below.

Maximum Span C

	2,250 RPM	2,000 RPM	1,750 RPM	1,500 RPM	1,250 RPM	1,000 RPM	900 RPM	750 RPM	650 RPM	500 RPM
	Inch (mm)	Inch (mm)	Inch (mm)	Inch (mm)	Inch (mm)	Inch (mm)	Inch (mm)	Inch (mm)	Inch (mm)	Inch (mm)
6F22 6F22C	46.9 (1,193)	49.8 (1,265)	53.2 (1,352)	57.5 (1,461)	63.0 (1,600)	70.4 (1,789)	74.2 (1,886)	81.3 (2,066)	87.4 (2,219)	99.6 (2,530)
6F26 6F26C	52.5 (1,332)	55.6 (1,413)	59.5 (1,511)	64.2 (1,632)	70.4 (1,787)	78.7 (1,998)	82.9 (2,107)	90.9 (2,308)	97.6 (2,479)	111.3 (2,826)
6F30 6F30C	52.5 (1,332)	55.6 (1,413)	59.5 (1,511)	64.2 (1,632)	70.4 (1,787)	78.7 (1,998)	82.9 (2,107)	90.9 (2,308)	97.6 (2,479)	111.3 (2,826)
6F37 6F37C	51.0 (1,295)	67.3 (1,709)	75.4 (1,915)	81.4 (2,068)	89.2 (2,266)	99.7 (2,533)	105.1 (2,670)	115.2 (2,925)	123.7 (3,142)	141.0 (3,582)
6F45 6F45C	59.5 (1,511)	79.2 (2,012)	84.9 (2,157)	91.7 (2,330)	100.5 (2,553)	112.4 (2,854)	118.4 (3,008)	129.7 (3,295)	139.4 (3,540)	158.9 (4,036)
6F52 6F52C	25.8 (655)	38.7 (983)	57.6 (1,463)	86.7 (2,202)	105.5 (2,681)	118.0 (2,997)	124.4 (3,159)	136.3 (3,461)	146.4 (3,718)	166.9 (4,239)
6F60 6F60C	33.2 (843)	49.0 (1,245)	71.8 (1,824)	103.0 (2,616)	112.8 (2,866)	126.1 (3,204)	133.0 (3,377)	145.7 (3,700)	156.5 (3,974)	178.4 (4,531)
6F67 6F67C	32.5 (826)	49.3 (1,252)	73.9 (1,877)	111.8 (2,840)	124.0 (3,150)	138.7 (3,522)	146.2 (3,713)	160.1 (4,067)	172.0 (4,369)	196.1 (4,981)



Dynamic Balancing Guidelines for CD Floating Shaft Couplings

The close tolerances used to manufacture CD Couplings in conjunction with the Composite Disc pack make CD Floating Shaft Couplings especially well suited to high speed and long span applications. Occasionally, the application may require dynamic balancing of the floating shaft coupling. See graph for general application guidelines. **Contact factory for more detail.**

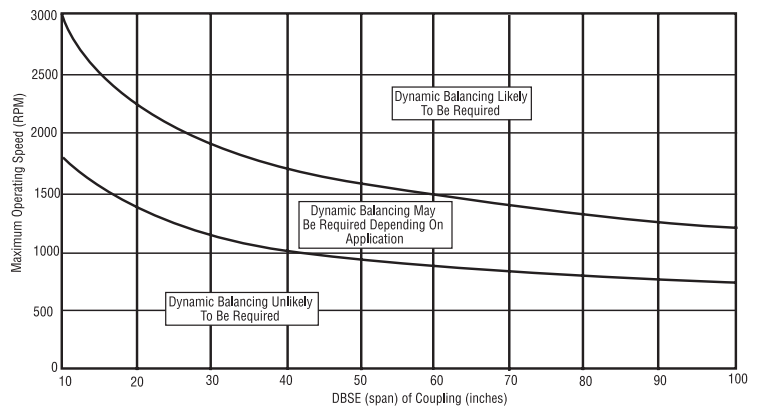

Coupling Misalignment

In general, the misalignment capacity of CD Floating Shaft Couplings is related to the speed at which they operate and the mass of the floating shaft, which is governed by its diameter and length. The table to the right shows recommended maximum allowable angular misalignment.

By reducing the allowable misalignment (and therefore stresses in the disc packs) at higher operating speeds and longer DBSEs, the disc pack can better support and stabilize the floating shaft, which will result in longer coupling life, smoother operation, and less vibration on the connected equipment. **Contact us for application assistance.**

DBSE (Distance "C")

	Up to 30"	30" - 60"	Over 60"
To 500 RPM	3°	2.5°	2°
500 - 1,000 RPM	2.5°	2°	1.5°
1,000 - 1,500 RPM	2°	1.5°	1°
Above 1,500 RPM	1°	0.75°	0.50°

For long spans between motion components, special CD Floating Shaft Couplings are the answer.

Any of the hub options (A, B and Clamp style) are available.

Special floating shaft materials are available including aluminum, steel, and stainless steel.

Special finishes to shaft and hub components are available including nickel plating, zinc plating, and others.

Contact Zero-Max for recommendations.

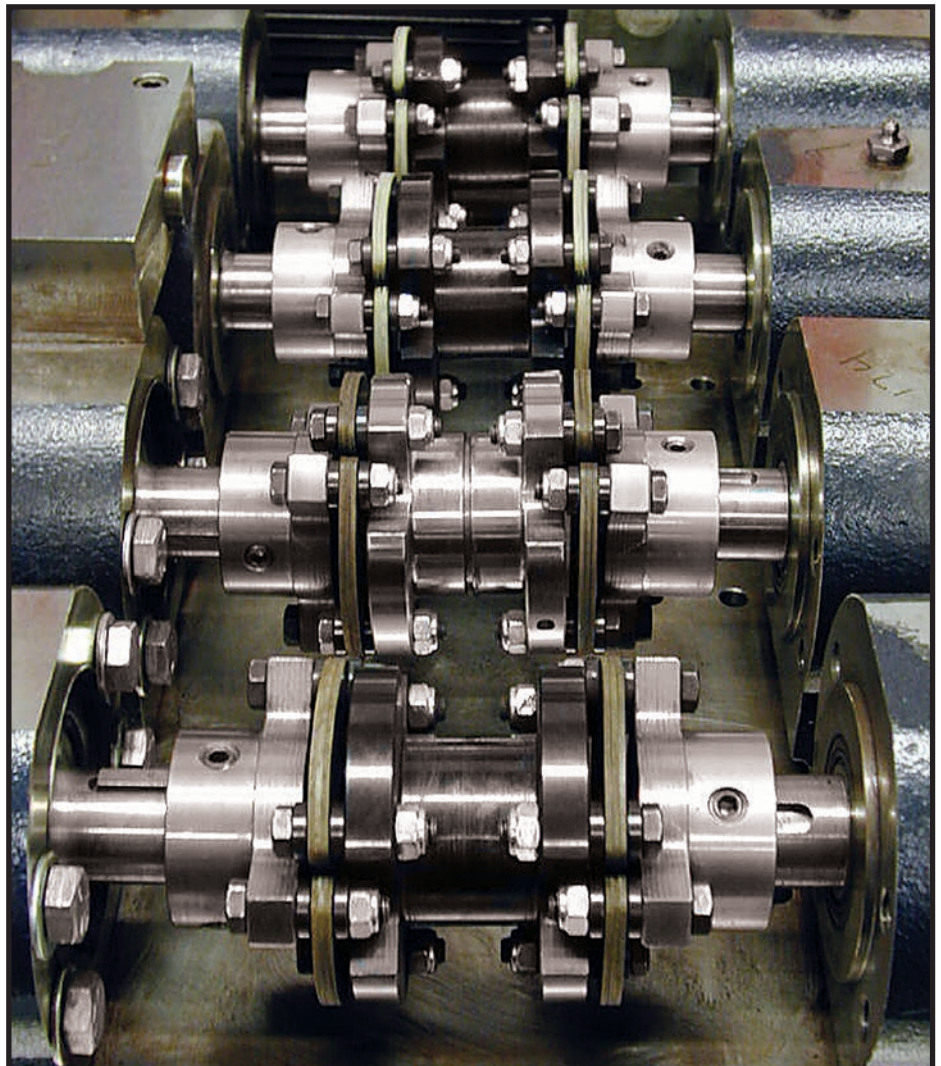

Floating Shaft Couplings on test in the Zero-Max test lab. This system is designed to run continuously at high misalignment, subjecting the composite unitized disc packs to billions of flexural fatigue cycles.

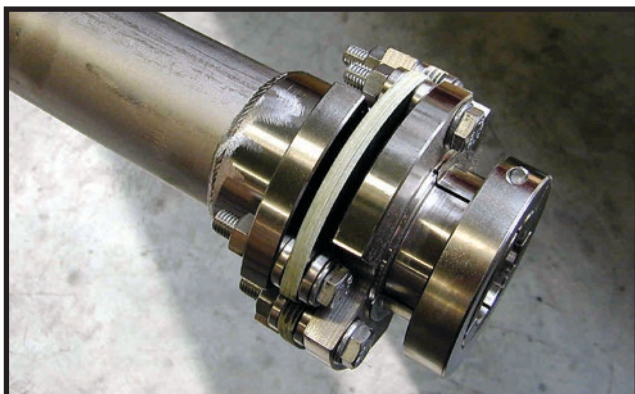

Clamp style hubs on the Composite Disc Floating Shaft Coupling provide an effective and secure shaft attachment.



Nickel plated CD Floating Shaft Coupling provides effective corrosion protection.

Custom designs.

No application is too large, too small, or too difficult for a CD Coupling. Zero-Max has the ability to provide imaginative solutions for virtually every coupling need.

Design Engineering Assistance.

From the first contact you have with our factory trained and supported Representative, to the completion of the approval drawing, Zero-Max will provide quality service throughout the process. Zero-Max Engineering is continually involved in custom projects with the latest technology available to solve your coupling needs. Our recommendations are based on decades of coupling experience.



Need higher misalignment and greater torque capacity in your coupling? Need more flexibility and torsional stiffness too? Need to fit a high performance coupling in a really small space? Need a really large bore diameter coupling or a very long floating shaft coupling? It is likely that a standard CD Coupling will satisfy your requirements. If it doesn't, we'll quickly design a solution using our Finite Element Analysis (FEA). With experience from thousands of different applications, our extensive FEA database brings instant answers to your questions.



Key Is The Patented Disc Design.

The key to the high performance capabilities of the CD Coupling lies in the Composite Disc pack. Everything about this unique part contributes to its high performance characteristics.

The shape, the cutting process, the material used, the order and the orientation of the layers, and even the coating used have important significance. Zero-Max has been perfecting this design for decades and has accumulated a vast database of solutions.

Finite Element Analysis Tailors Disc to Application.

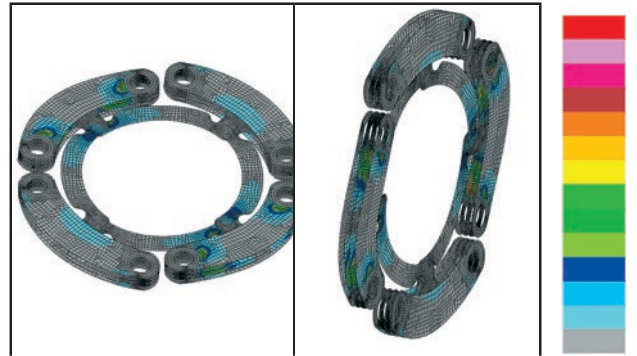

Using Finite Element Analysis (FEA), the disc design can be easily modified along with changes in the composite material. Custom disc designs (manufactured on state-of-the-art laser cutting machines) can add to or lessen coupling flexibility or increase strength and stiffness as required for the particular application. There are over

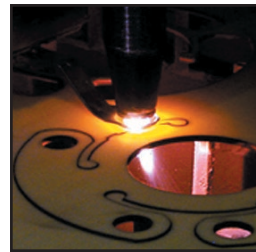

100 standard models and sizes of CD Couplings for most applications. For applications outside this range, special CD Couplings can be designed and produced cost effectively, in any quantity, within your delivery requirements.

Design, Analysis, Testing Programs, and Production Capabilities are all geared toward supplying the correct coupling at the lowest cost and in the shortest lead time.

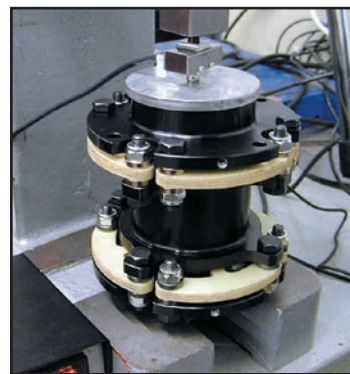

Coupling Axial Stiffness Test

The Zero-Max test laboratory is capable of all types of static and dynamic testing to ensure that the design specifications are met.

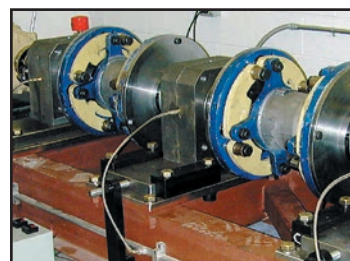

Full scale durability test of two wind generator couplings under extreme misalignment conditions

Production of CD Couplings is executed with modern CNC machinery, which provides components with the accuracy required for demanding applications. Quality Control of all manufacturing processes, guarantees that CD Couplings will meet strict performance requirements.

Zero-Max is ISO 9001:2015 Certified

High Power in a small space

This allowed our customer to use a smaller machine base.



High Speed Couplings

This coupling uses low inertia hub design for exceptionally high speed applications.



Large Scale Floating Shaft Couplings

High Power Wind Turbines require long life and superior flexibility.



High Misalignment and High Torque

Composite materials of disc packs offer longer life and higher performance than metal disc packs.



Custom Stiffness

Custom Disc pack and hubs to meet critical application requirements.

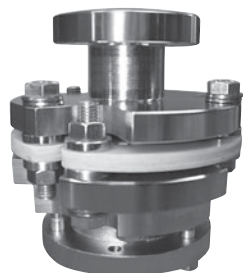

Shrink Disc Clamping Hubs

Special hubs for high torque keyless shaft applications.



QD Bushing Couplings

Single-Flex Coupling has machined hubs to accept standard QD bushings.



Phase Adjustable Couplings

Special Double-Flex Coupling has built-in phase adjuster for use in printing presses.

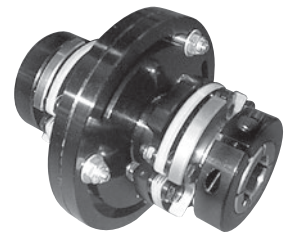

Blind Fit Couplings

Coupling is designed so tool-less axial assembly is possible without disassembly of the surrounding components.

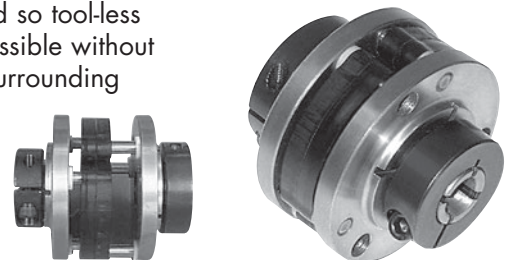

Before and After Assembly

High Misalignment and High Torque

Composite materials of disc packs offer longer life than metal disc packs.



Nickel Plated Couplings

For applications requiring frequent washdowns.

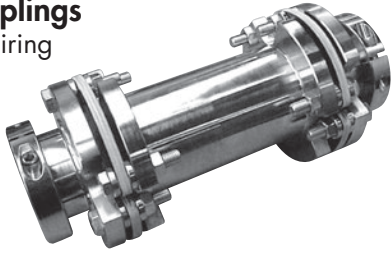

Torque Transducer Coupling

Special spacer coupling has built-in torque transducer for use on a test fixture.

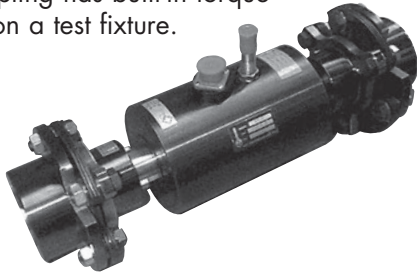

Aluminum Floating Shaft Couplings

For high speed operation.



Large Scale Floating shaft

For large scale printing application. Very high torsional stiffness for precise registrations.



High Precision in a small package

Double-Flex, clamp hubs only 1.6" wide to fit small space envelope.



Modified Discs For Increased Performance.

Zero-Max is committed to excellence and complete customer satisfaction. Every custom CD Coupling must first exceed our performance expectations before production and delivery to you.

Call or email today to discuss your custom CD Coupling needs 800-533-1731
www.zero-max.com

Longer Arm Disc Design Yields Greater Coupling Flexibility and misalignment capacity.



Shorter Arm Disc Design Yields Greater Coupling Rigidity



Custom 12 bolt design
Ultra high torsional stiffness with flexibility.



Custom Disc Packs
To meet custom designs and challenging applications.



Information Required

- Continuous and peak torque requirements, and/or motor HP.
- Maximum Coupling RPM.
- Distance Between Shaft Ends (DBSE).
- Service factor.
- Misalignment requirements.
- Physical space limitations.
- Hub bores, with or without keyways.
- Other environmental considerations.

Selection Procedure

1. Select a coupling type (Single-Flex, Double-Flex, or Floating Shaft) based on misalignment requirement and/or DBSE (Distance Between Shaft Ends).
2. Determine the required service factor.
3. If continuous torque is known, then multiply it by the required service factor to get the Design Torque:
Design Torque (in-lbs) = Continuous Torque (in-lbs) x Service Factor
 If continuous torque is not known, but Horsepower and RPM are, calculate the design torque by using this formula:
Design Torque (in-lbs) = $\frac{HP \times 63,000 \times Service\ Factor}{Coupling\ RPM}$
4. Select a coupling size that has a continuous torque rating equal to or greater than the Design Torque calculated in step 3. Make sure that the peak torque of the application does not exceed the maximum torque rating of the coupling.
5. Check coupling RPM to be sure it is within the rated maximum speed. Consult with factory if your speed exceeds the ratings – we have made many special couplings that greatly exceed these ratings.
6. Make sure that the misalignment capability is sufficient. As with all couplings, there is a trade-off between the parallel, angular, and axial misalignment capabilities. Be certain that the **combined percentages** of each do not exceed 100%. *If you have a question on combined misalignments, consult the factory.* It is always best to select a coupling with misalignment capabilities exceeding the initial operating conditions to allow for changing conditions over the operating life of the machine.
7. Check to be sure that the coupling fits the required dimensions such as available space envelope and bore sizes.
8. If the coupling size and type meet the torque, misalignment, and space envelope criteria, the selection is complete.

Note: If the standard couplings listed in the catalog do not meet your requirements, please consult the factory. We will work with you to meet your needs.



Single-Flex



Double-Flex



Floating Shaft



Call Factory for Customs

6	Type	Size*	Hub-Style	(Bore 1	Keyway Specification**	X	Bore 2	Keyway Specification**)
	A = Single-Flex P = Double-Flex F = Floating Shaft	18 52 22 60 26 67 30 90 37 105 45 120	(omit) = Steel Set-Screw Hubs C = Steel Clamp Style Hubs -AC = Aluminum Clamp Style Hubs -A1C = Integrated Collar Aluminum Clamp Hubs -SS = Stainless Steel Set-Screw Hubs C-SS = Stainless Steel Clamp Style Hubs QD = QD Style Hubs		Specify "mm" or "inches"	KEY = with Keyway NKW = No Keyway		** Standard Size Keyways (See charts below)	Specify "mm" or "inches"	

*See Catalog for available sizes of each Hub-Style

Bore sizes are based on the nominal shaft diameters, as documented by the AGMA Standard 511.02 (Bore and Keyway Sizes for Flexible Couplings). All clearance fits (standard) are according with the ANSI B4.2 (imperial) and with the ISO 286-1 (metric).

NOTE: The Distance Between Shaft Ends (DBSE) dimension must be added to the 6F__ (Floating Shaft) style Couplings part number

NOTE: The hub design of Series A1C CD Couplings will provide the necessary clamping force to hold the shaft in a dynamic application without the use of keyways for all bore sizes listed in catalog.

Example:

6A30-A1C (20mm NKW x 1.500" KEY)

- * Single-Flex
- * Size 30
- * A1C Style Hubs
- * 20mm bore w/o Keyway x 1.500" bore w/Keyway

Standard Keyways
Inch Bore Hubs

Bore Size		Keyway	Bore Size		Keyway
Over	To		Over	To	
0.437	0.562	0.125 x 0.062	2.250	2.750	0.625 x 0.312
0.562	0.875	0.187 x 0.094	2.750	3.250	0.750 x 0.375
0.875	1.250	0.250 x 0.125	3.250	3.750	0.875 x 0.437
1.250	1.375	0.312 x 0.156	3.750	4.500	1.000 x 0.500
1.375	1.750	0.375 x 0.187	4.500	5.500	1.250 x 0.625
1.750	2.250	0.500 x 0.250	5.500	6.500	1.500 x 0.750

Note: Inch bore set-screw hubs will be supplied with inch size set-screws.

Standard Keyways
Metric Bore Hubs

Bore Size		Keyway	Bore Size		Keyway
Over	To		Over	To	
10	12	4 x 1.8	58	65	18 x 4.4
12	17	5 x 2.3	65	75	20 x 4.9
17	22	6 x 2.8	75	85	22 x 5.4
22	30	8 x 3.3	85	95	25 x 5.4
30	38	10 x 3.3	95	110	28 x 6.4
38	44	12 x 3.3	110	130	32 x 7.4
44	50	14 x 3.8	130	150	36 x 8.4
50	58	16 x 4.3	150	170	40 x 9.4

Note: Metric bore set-screw hubs will be supplied with metric size set-screws.



6A37C (38mm KEY x 1.750" NKW)

Download CAD

View 3D Model [Adobe 3D PDF help](#)

Configuration

Bore Size D1	38 mm
d1 Keyway Option	YES
Bore Size D2	1.7500"
d2 Keyway Option	NO



Zero-Max Configurable
3D CAD Downloads.
www.zero-max.com

PRECISE. RELIABLE. ROBUST. AVAILABLE.

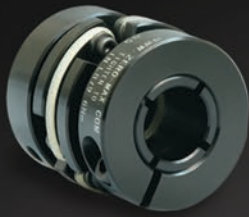

CD® Couplings

High-performance couplings that outperform and outlast bellows and steel disc designs. The unique design of the composite disc enables the CD Couplings to withstand punishing applications and deliver high precision performance. Fully Customizable.



Keyless Shaft Locking Devices

ETP® keyless connections and Posi-Lok® keyless bushings provide quick, easy and accurate assembly of mounted shaft components. Both inch and metric bore sizes are available from stock.



ServoClass® Couplings

Designed for demanding servomotor applications. Zero backlash, high torsional stiffness, high speed design. Features flexible metal discs for high misalignment capacity and keyless clamp-type mounting hubs.

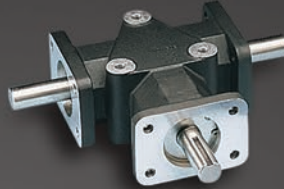

Crown Gear Drives

Available in 5-sizes, 3 configurations, and with 1:1 and 2:1 ratios. High quality AGMA class 10 spiral bevel gears. Stainless steel shafts and either black anodized or IP65-Rated nickel-plated aluminum housing.



Schmidt Offset Couplings

Designed to handle high amounts (up to 17") of parallel shaft offset with constant angular velocity. Standard models with torque capacities up to 459,000 in-lbs and extensive custom capabilities.



Adjustable Speed Drives

Easy to install and maintenance free. Zero-Max® Drives offer infinitely variable speeds from 0 rpm to 1/4 of input rpm. 5 models with torque ranges from 12 in-lbs to 200 in-lbs.

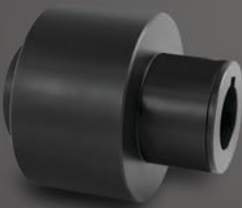

Overload Safety Couplings

Torque Tender® Couplings provide reliable overload protection in any mechanical power transmission system. Full selection of styles and sizes with set-point torque ranges from 3 to 3,000 in-lbs.



Roh'Lix® Linear Actuators

Simple conversion of rotary motion into precise linear motion. Available in five models and multiple configurations. Roh'Lix actuators have thrust ratings from 5 to 200 lbs. All models feature built-in overload protection.



Control-Flex Couplings

Zero backlash couplings designed for encoder and instrumentation type applications. Features high misalignment capacity, constant velocity, and an electrically isolated hub design.

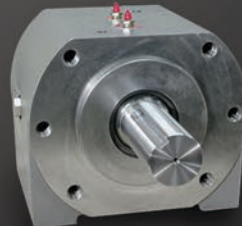

OHLA® Overhung Load Adaptors

Designed to protect hydraulic motors and pumps from radial/axial loads and to provide additional seal protection. 11 models available for mounts from SAE A to SAE F. Fully customizable.

Warranty. Zero-Max, Inc. the manufacturer, warrants that for a period of 12 months from date of shipment it will repair, or at its option, replace any new apparatus which proves defective in material or workmanship, or which does not conform to applicable drawings and specifications approved by the manufacturer. All repairs and replacements shall be F.O.B. factory. All claims must be made in writing to the manufacturer. ● In no event and under no circumstances shall manufacturer be liable for (a) damages in shipment; (b) failures or damages due to misuse, abuse, improper installation or abnormal conditions of temperature, dirt, water or corrosives; (c) failures due to operation, intentional or otherwise, above rated capacities, and (d) non-authorized expenses for removal, inspection, transportation, repair or rework. Nor shall manufacturer ever be liable for consequential and incidental damages, or in any amount greater than the purchase price of the apparatus. ● Zero Max, Inc. reserves the right to discontinue models or to change specifications at any time without notice. No discontinuance or change shall create any liability on the part of Zero-Max, Inc. in respect to its products in the hands of customers or products on order not incorporating such changes even though delivered after any such change. ● This warranty is in LIEU OF ALL OTHER WARRANTIES, EXPRESS OR IMPLIED, INCLUDING (BUT NOT LIMITED TO) ANY IMPLIED WARRANTIES OF MERCHANTABILITY OR FITNESS FOR A PARTICULAR PURPOSE. THE TERMS OF THIS WARRANTY CONSTITUTE ALL BUYER'S OR USER'S SOLE AND EXCLUSIVE REMEDY, AND ARE IN LIEU OF ANY RIGHT TO RECOVER FOR NEGLIGENCE, BREACH OF WARRANTY, STRICT TORT LIABILITY OR UPON ANY OTHER THEORY. Any legal proceedings arising out of the sale or use of this apparatus must be commenced within 18 months of the date of purchase. ● CAUTION: Rotating equipment must be guarded. Also refer to OSHA specifications and recommendations. ● Zero-Max®, CD®, ETP®, ServoClass®, Torq-Tender®, Posi-Lok®, Roh'Lix®, and OHLA® are registered trademarks of Zero-Max, Inc. In U.S.A.

©Zero-Max, Inc., All Rights Reserved
Printed in U.S.A., Rev2.025

////// ZERO-MAX®

13200 Sixth Avenue North, Plymouth, Minnesota 55441-5509
Phone 800.533.1731 763.546.4300 FAX 763.546.8260

zero-max.com